

Job Name _____
 Purchaser _____
 Submitted to _____
 Unit Designation _____

Location _____
 Engineer _____
 Reference _____ Approval _____ Construction _____
 Schedule # _____

Specifications

Model	Indoor Unit Model Number (US Code)	AC030KNZDCH/AA (CNH30ZDK)		
	Outdoor Unit Model Number (US Code)	AC030JXADCH/AA (CXH30ADJ)		
Performance	Nominal Capacity ¹	Cooling / Heating (Btu/h)	30,000 / 32,000	
	Capacity Range	Cooling (Btu/h)	10,000 - 33,000	
		Heating (Btu/h)	9,000 - 36,000	
	SEER / EER		19.6 / 10.5	
	COP (nominal heating)		3.33	
	HSPF		10.4	
	AHRI Certification Number		8950561	
Condensate (pints/h)		6.76		
Power (without optional heat kits)	Voltage	ø / V / Hz	1 / 208-230 / 60	
	Working Voltage Range (VAC)		176 - 254 (max. 3% deviation from each)	
	Operating Current (min. / std. / max.)	Cooling (A)		4.5 / 13.0 / 17.2
		Heating (A)		4.1 / 12.3 / 20.2
	Max. Breaker	Amps		35
Min. Circuit Ampacity (A)			21.7	
Dimensions	W X H X D (in.)	Indoor Unit	21 X 48 X 21	
		Outdoor Unit	37 X 39 11/16 X 13	
	Weight (lbs.)	Indoor Unit	123.5	
		Outdoor Unit	154.8	
Sound Pressure Level	Indoor Unit dB(A)	L / M / H	35 / 38 / 41	
	Outdoor Unit dB(A)	Cooling / Heating (high)	50 / 52	
Operating Temperatures °F(°C)	Outdoor	Cooling	23 ~ 115°F(-5 ~ 46°C) 0 ~ 115°F(-18 ~ 46°C) W/Baffle	
		Heating	-4 ~ 76°F(-20 ~ 24°C)	
	Indoor	Cooling	61 ~ 90°F(16 ~ 32°C)	
		Heating	T ≤ 80°F(27°C)	
Pipe Connections	Indoor & Outdoor	High side (flare)	3/8"	
		Low side (flare)	5/8"	
	Maximum (ft.)		164	
	Maximum Vertical Separation (ft.)		98	
Condensate Connection			3/4" FNPT	
Refrigerant	Factory Charge	oz.	91.71	
	Charged for		25 ft	
	Additional Refrigerant		0.24 oz./ft. over 25 ft	
Compressor	Type		Inverter Driven, Twin BLDC Rotary	
	RLA	A	15.1	
Evaporator Fan	Type		Double-inlet, forward curve, centrifugal (with ECM motor)	
	Air Volume	CFM (L/M/H)	848 / 918 / 1,007 (at standard ESP)	
		Total CFM Range ²		419 - 1,314
	HP			1/2
	Motor Amps	A		1.66
	External Static Pressure ("WC)	Standard		0.24
	Min. / Max.		0 / 1.0	
Condenser Fan	Motor		BLDC With Axial Type Fan (1)	
	FLA / Watts / CFM (max.)		0.48 A / 125 W / 2,200 CFM	
Safety	Certifications		ETL (UL 1995)	
	Devices: PCB fuses, indoor unit terminal block thermal fuse, current transformer, over-voltage protection, crankcase heating, temperature limit protection logic, compressor overload sensing			



General Information

- Auto-restart after power loss
- The indoor unit shall be capable of being field convertible to downflow configuration with optional downflow conversion kit.
- The outdoor unit shall have a snow accumulation prevention option setting to prevent snow drifting against an idle outdoor unit.
- The indoor and outdoor units shall have a removable EEPROM that stores system programming information, unit name, and other data
- The outdoor unit shall have a night time quiet mode option to reduce operating sound during the night (automatic or manual activation with dry contact signal).
- The pipe connections at the outdoor unit shall be internal allowing pipes to enter the chassis through the front, right side, bottom, or back.
- Air handler has an air leakage of no more than 2 percent of the design air flow rate when tested in accordance with ASHRAE 193.
- The outdoor unit shall supply power to indoor unit via 14 AWG X 3 power wire when optional heat kits are not installed. If VHK-***A supplemental heat kits are installed, power to the heat kits must be provided from a dedicated circuit with proper overcurrent protection per NEC (refer to VHK-***A supporting documents for heat kit electrical data).

Construction

The outdoor unit shall be galvanized steel with a baked on powder coated finish for durability

The indoor unit shall be constructed of insulated, powder coated, galvanized steel

Indoor Fan
 The indoor fan is a double-inlet, forward curve, centrifugal type with a single constant-torque (ECM) fan motor

The indoor unit shall have low, medium, high, and auto fan speed setting options.

The evaporator fan motor shall have five speed taps

Heat Exchanger
 The indoor unit heat exchanger shall be mechanically bonded aluminum fin to copper tube

The outdoor unit heat exchanger shall be aluminum, flat fin, micro channel

Controls

Control signal shall be a DDC type signal

Interconnect control wire between outdoor and indoor unit shall be 16AWG X 2 shielded

Controllers must be purchased separately

Controls shall integrate with a BMS system

No additional interface modules/adapters are required when connecting to Samsung NASA DVM S central controllers.

Refrigerant System

The refrigerant type shall be R410A

The compressor shall be hermetically sealed, inverter controlled, twin BLDC Rotary made by Samsung

Refrigerant flow shall be controlled by an electronic expansion valve at outdoor unit

Soft-start to reduce current demand during compressor start

Warranty

10 Years compressor, 10 years parts, 1 year limited labor when registered (conditions apply)

¹ Certified in accordance with the AHRI Unitary Small Air-Source Heat Pumps (USHP) Certification Program which is based on the latest edition of AHRI Standard 210/240.
² Refer to installation manual for full fan curve details



Optional Accessories

Wired Controller	Advanced Wired Controller	MWR-WG00UN
	Simplified Touch Controller	MWR-SH11UN
Wi-Fi Adapter		MIM-H04UN
Wireless Signal Control	Wireless Signal Receiver	MRK-A10N
	Wireless Controller	AR-EH03U
External Temperature Sensor		MRW-TA
External Contact Control		MIM-B14
Filter Box (includes 1" MERV 8 filter)		VFB-2
Supplemental Electric Heat Kits	5kW	VHK-205A
	10kW	VHK-210A
Wall Bracket (for outdoor unit)		CKN-250
Wind Baffles	Front	WBF-2M-B
	Back	WBB-3M
Line Sets - insulated and flared, interconnect cables included		25' - ILS2510
		50' - ILS5010
Downflow Conversion Kit		VDK-2
Thermostat Adaptor (for connection to a standard 24VAC thermostat)		MIM-A60UN

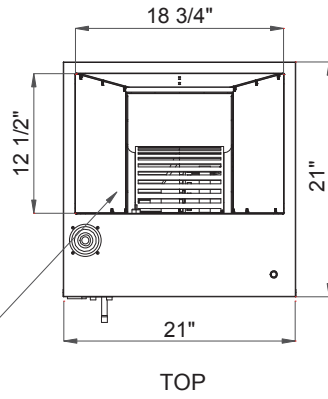

No.	Description
①	Gas Pipe
②	Liquid Pipe
③	Drain Connection
④	Air Outlet
⑤	Air Inlet

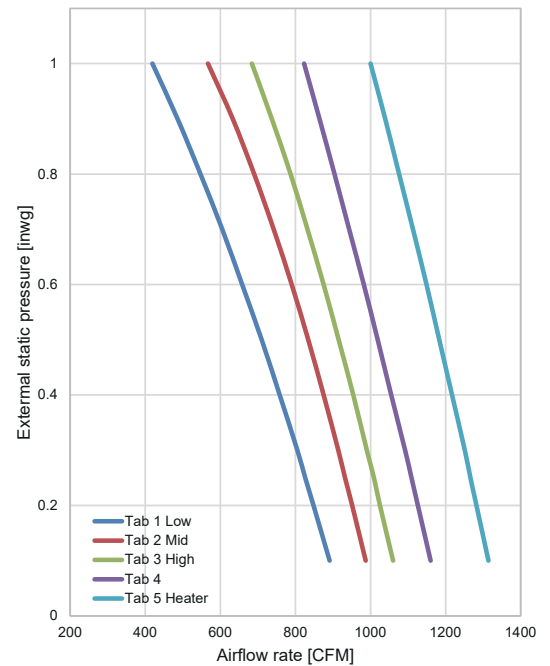
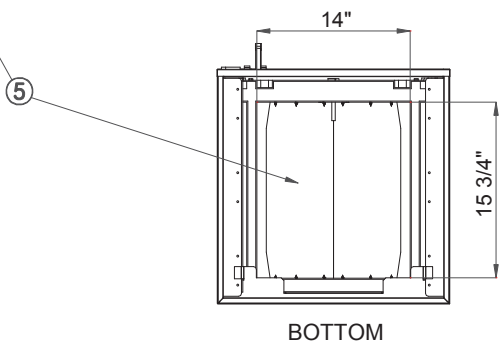
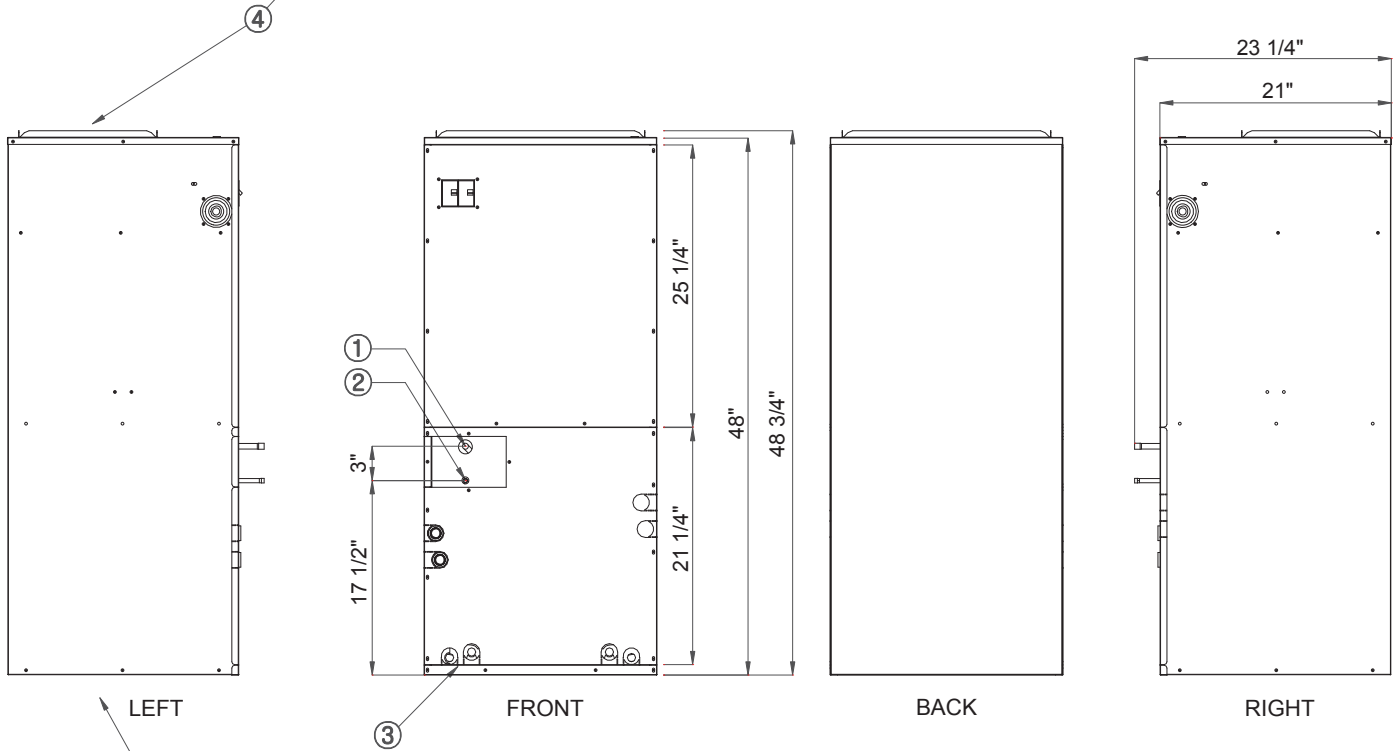

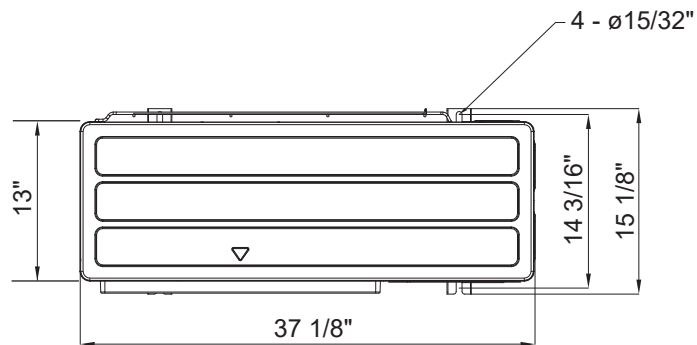

TOP

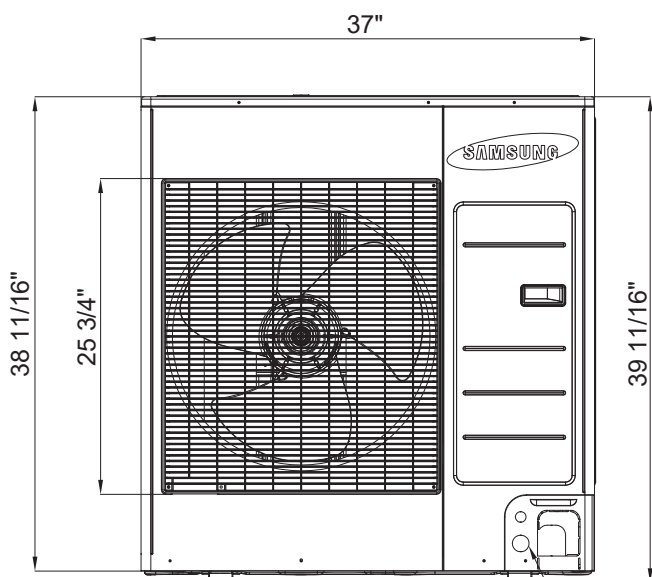

FRONT

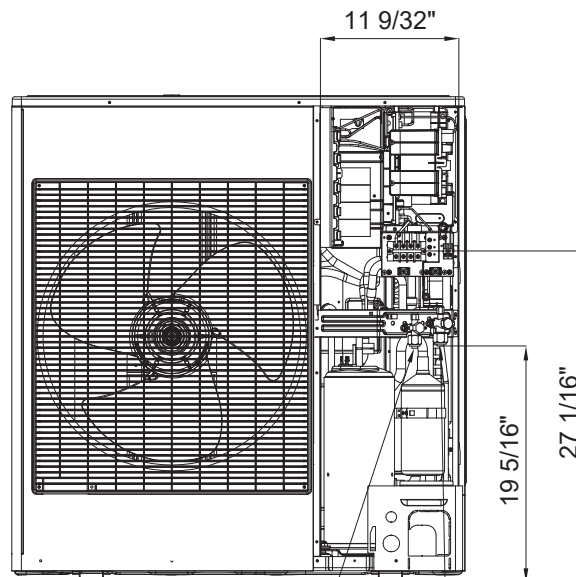

FRONT WITHOUT SERVICE COVER

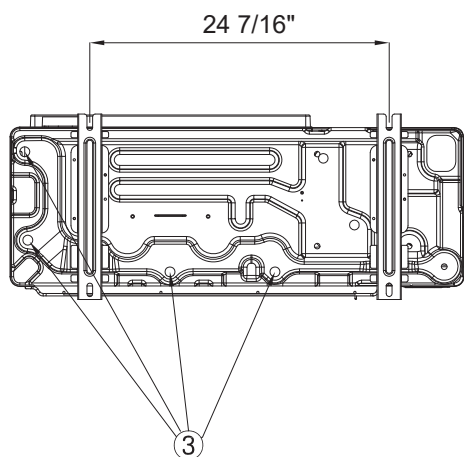

No.	Description
1	Suction service valve
2	Liquid service valve
3	Drainage hole
4	Power and communication conduit openings