

Job Name \_\_\_\_\_  
 Purchaser \_\_\_\_\_  
 Submitted to \_\_\_\_\_  
 Unit Designation \_\_\_\_\_

Location \_\_\_\_\_  
 Engineer \_\_\_\_\_  
 Reference Approval Construction  
 Schedule # \_\_\_\_\_

**Specifications**

Model	Indoor Unit Model Number	AC054KNZDCH/AA		
	Outdoor Unit Model Number	AC054KXADCH/AA		
Performance	Nominal Capacity <sup>1</sup>	Cooling / Heating (Btu/h)	54,000 / 60,000	
	Capacity Range	Cooling (Btu/h)	21,000 - 55,000	
		Heating (Btu/h)	21,000 - 62,000	
	SEER / EER	17.10 / 8.05		
	COP (nominal heating)	3.03		
	HSPF	9.0		
	AHRI Certification Number	8950575		
	Condensate (pints/h)	12.05		
Power (without optional heat kits)	Voltage	ø / V / Hz	1 / 208-230 / 60	
	Working Voltage Range (VAC)	176 - 254 (max. 3% deviation from each)		
	Operating Current (min. / std. / max.)	Cooling (A)	10.1 / 28.7 / 35.8	
		Heating (A)	10.2 / 24.7 / 38.5	
	Max. Breaker	Amps	70	
Min. Circuit Ampacity (A)	42			
Dimensions	W X H X D (in)	Indoor Unit	24 1/2 X 58 3/4 X 21 3/4	
		Outdoor Unit	37 X 56 X 13	
	Weight (lbs.)	Indoor Unit	163.14	
		Outdoor Unit	211.6	
Sound Pressure Level	Indoor Unit dB(A)	L / M / H	39 / 42 / 45	
	Outdoor Unit dB(A)	Cooling / Heating (high)	56 / 56	
Operating Temperatures (°F)	Outdoor	Cooling	23 ~ 115°F(-5 ~ 46°C)	
		Heating	0 ~ 115°F(-18 ~ 46°C) W/Baffle	
	Indoor	Cooling	-4 ~ 76°F(-20 ~ 24°C)	
		Heating	61 ~ 90°F(16 ~ 32°C) T ≤ 80°F(27°C)	
Pipe Connections	Indoor & Outdoor	High side (flare)	3/8"	
		Low side (flare)	3/4"	
	Maximum (ft.)	246		
	Maximum Vertical Separation (ft.)	98		
	Condensate Connection	3/4" FNPT		
Refrigerant	Factory Charge	oz.	119.93	
	Charged for	25 ft		
	Additional Refrigerant	0.355 oz./ft. over 25 ft		
Compressor	Type	Inverter Driven, Twin BLDC Rotary		
	RLA	A	28.5	
Evaporator Fan	Type	Double-inlet, forward curve, centrifugal (with ECM motor)		
	Air Volume	CFM (L/M/H)	1,342 / 1,501 / 1,889 (at standard ESP)	
		Total CFM Range <sup>2</sup>	370 - 2,000	
	HP	3/4		
	Motor Amps	A	2.09	
External Static Pressure ("WC)	Standard	0.28		
	Min. / Max.	0.1 / 1.0		
Condenser Fan	Motor	BLDC With Axial Type Fan (2)		
	FLA / Watts / CFM (max.)	0.48 A X 2 / 125 W X 2 / 5,160 CFM		
Optional Accessories	Wired Controller	Advanced Wired Controller	MWR-WG00UN	
		Simplified Touch Controller	MWR-SH11UN	
	Wi-Fi Adapter	MIM-H04UN		
	Wireless Signal Control	Wireless Signal Receiver	MRK-A10N	
		Wireless Controller	AR-EH03U	
	External Temperature Sensor	MRW-TA		
	External Contact Control	MIM-B14		
	Central Control Interface Module for Connection to DVM Plus Controls (non-NASA)	MIM-N01		
	Filter Box (includes 1" MERV 8 filter)	VFB-3		
	Supplemental Electric Heat Kits	5kW	VHK-305A	
		10kW	VHK-310A	
		15kW	VHK-315A	
	Wall Bracket (for outdoor unit)	CKN-250		
	Wind Baffles	Front	WBF-6M	
		Back	WBB-4M	
Downflow Conversion Kit	VDK-3			
Safety	Certifications	ETL (UL 1995)		
	Devices: PCB fuses, indoor unit terminal block thermal fuse, current transformer, over-voltage protection, crankcase heating, temperature limit protection logic, compressor overload sensing			



**General Information**

- Auto-restart after power loss
- The indoor unit shall be capable of being field convertible to downflow configuration with optional downflow conversion kit.
- The outdoor unit shall have a snow accumulation prevention option setting to prevent snow drifting against an idle outdoor unit.
- The indoor and outdoor units shall have a removable EEPROM that stores system programming information, unit name, and other data
- All indoor unit addressing and option settings shall be done digitally; the indoor unit does not contain rotary dials or setting switches.
- The outdoor unit shall have a night time quiet mode option to reduce operating sound during the night (automatic or manual activation with dry contact signal).
- The pipe connections at the outdoor unit shall be internal allowing pipes to enter the chassis through the front, right side, bottom, or back.
- Air handler has an air leakage of no more than 2 percent of the design air flow rate when tested in accordance with ASHRAE 193.
- The outdoor unit shall supply power to indoor unit via 14 AWG X 3 power wire when optional heat kits are not installed. If VHK-\*\*\*A supplemental heat kits are installed, power to the heat kits must be provided from a dedicated circuit with proper overcurrent protection per NEC (refer to VHK-\*\*\*A supporting documents for heat kit electrical data).

**Construction**

The outdoor unit shall be galvanized steel with a baked on powder coated finish for durability

The indoor unit shall be constructed of insulated, powder coated, galvanized steel

**Indoor Fan**  
 The indoor fan is a double-inlet, forward curve, centrifugal type with a single constant-torque (ECM) fan motor

The indoor unit shall have low, medium, high, and auto fan speed setting options.

The evaporator fan motor shall have five speed taps

**Heat Exchanger**  
 The indoor unit heat exchanger shall be mechanically bonded aluminum fin to copper tube

The outdoor unit heat exchanger shall be aluminum, flat fin, micro channel

**Controls**

Control signal shall be a DDC type signal

Interconnect control wire between outdoor indoor unit shall be 16AWG X 2 shielded

Controls must be purchased separately

Controls shall integrate with a BMS system

No additional interface modules/adapters are required when connecting to Samsung NASA DVM S central control.

**Refrigerant System**

The refrigerant type shall be R410A

The compressor shall be hermetically sealed, inverter controlled, twin BLDC Rotary made by Samsung

Refrigerant flow shall be controlled by an electronic expansion valve at outdoor unit

Soft-start to reduce current demand during compressor start

**Warranty**

10 Years compressor, 10 years parts, 1 year limited labor when registered (conditions apply)

<sup>1</sup> Certified in accordance with the AHRI Unitary Small Air-Source Heat Pumps (USHP) Certification Program which is based on the latest edition of AHRI Standard 210/240.  
<sup>2</sup> Refer to installation manual for full fan curve details



No.	Description
①	Gas Pipe
②	Liquid Pipe
③	Drain Connection
④	Air Outlet
⑤	Air Inlet

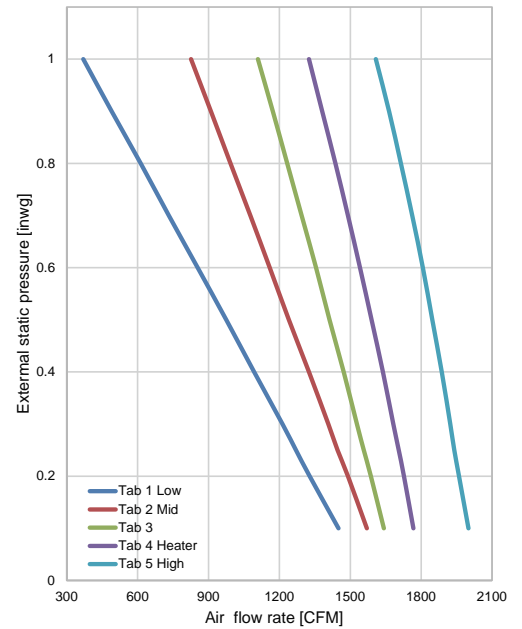
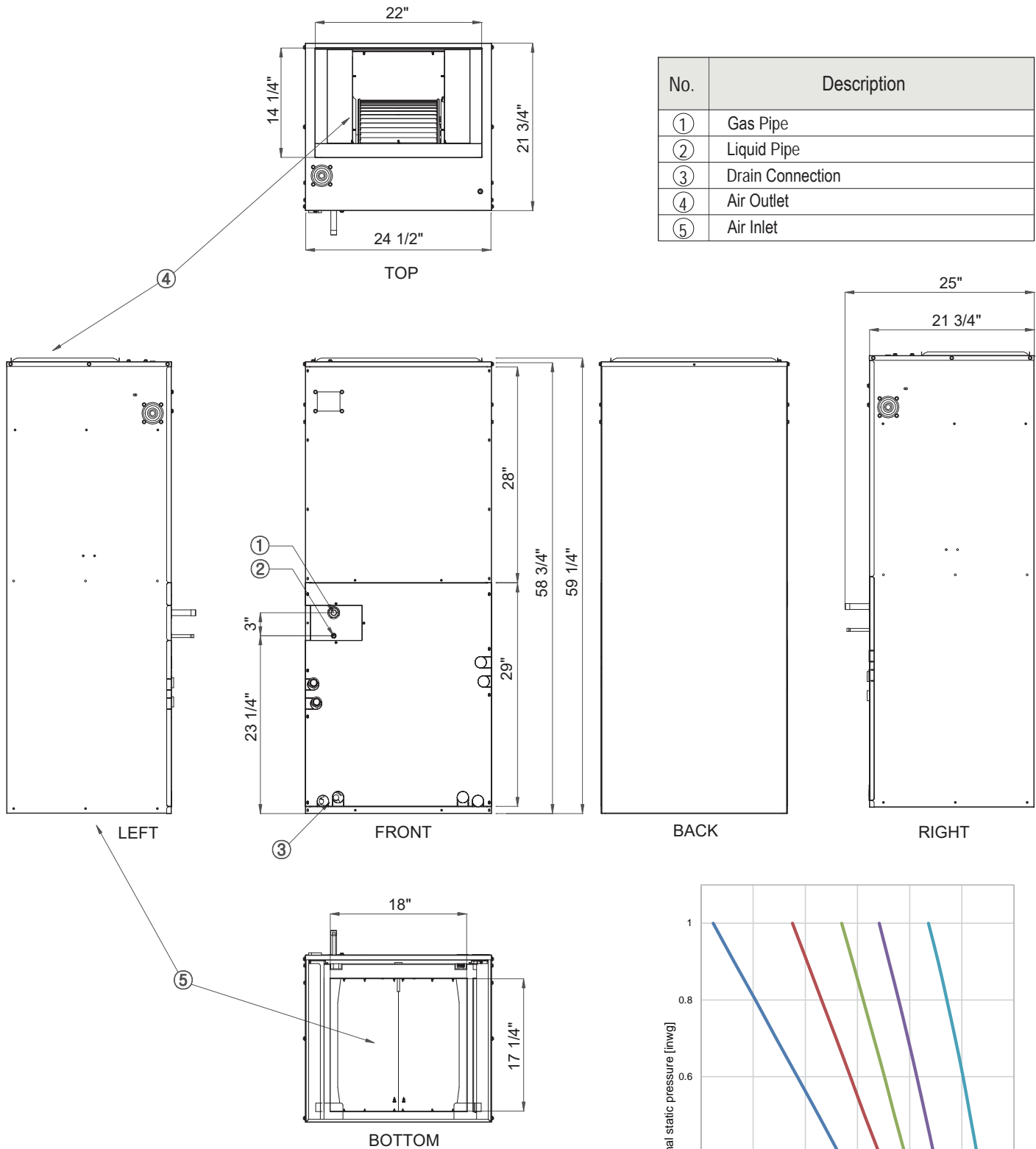

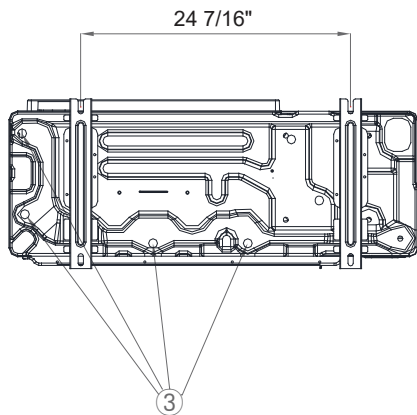
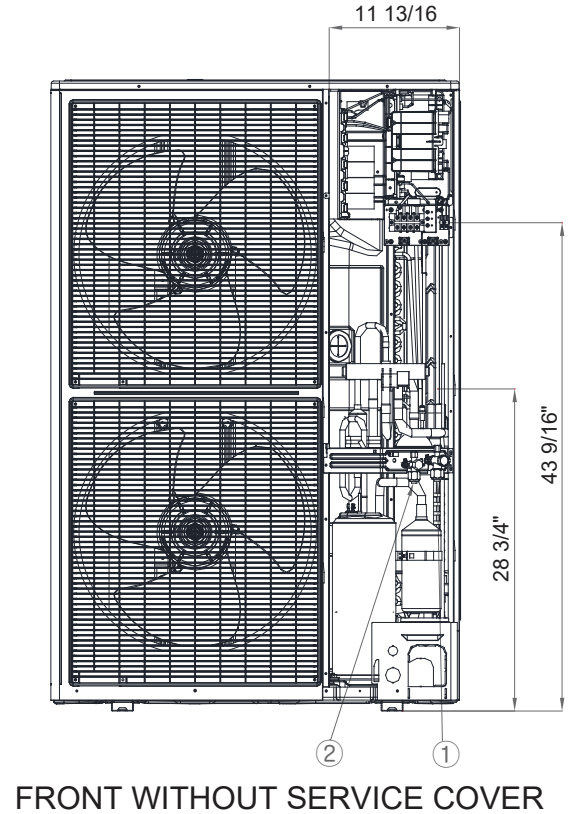
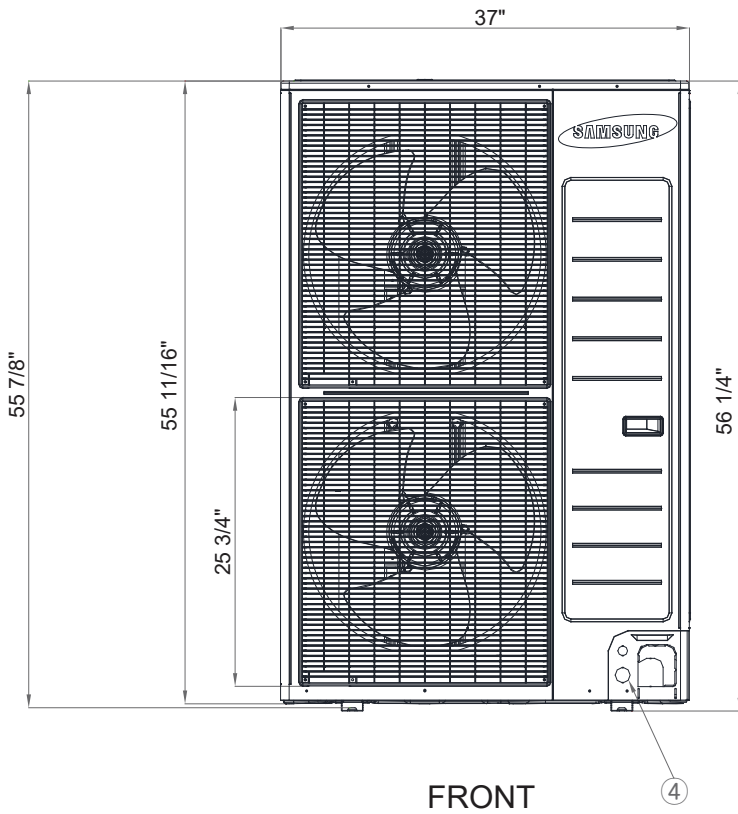
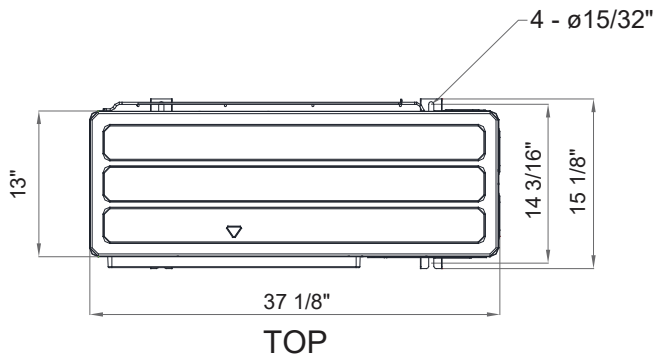

No.	Description
1	Suction service valve
2	Liquid service valve
3	Drainage hole
4	Power and communication conduit openings