

INSTALLATION AND MAINTENANCE INSTRUCTIONS

Variable Speed Electric Furnace

WARNING

Improper installation, adjustment, service, or maintenance can cause injury or property damage. Refer to this manual. For assistance or additional information, consult a qualified installer or service agency.

WARNING

The information contained in this manual is intended for use by qualified service technicians familiar with safety procedures and equipped with the proper tools and test instruments. Failure to carefully read and follow all instructions in this manual can result in equipment malfunction, property damage, personal injury, and/or death.

WARNING

Disconnect all power supplies to both the indoor blower section and outdoor section before making any electrical connections or servicing the system. More than one disconnect switch may be required to de-energize the equipment. Hazardous voltage can cause severe personal injury or death.

Manufactured By
A.A.C.
A Lennox International Company
421 Monroe Street
Bellevue, OH 44811



Inspection of Shipment

Upon receipt of equipment, carefully inspect it for possible shipping damage. If damage is found, it should be noted on the carrier's freight bill. Take special care to examine the unit inside the carton if the carton is damaged. Any concealed damage discovered should be reported to the last carrier immediately, preferably in writing, and should include a request for inspection by the carrier's agent.

If any damages are discovered and reported to the carrier **DO NOT INSTALL THE UNIT, as claim may be denied.**

Check the unit rating plate to confirm specifications are as ordered.

TABLE OF CONTENTS

SPECIFICATIONS	2
INSTALLATION	6
SETUP PROCEDURE	10
SEQUENCE OF OPERATION	12
SYSTEM CHECK	12
REPLACEMENT PARTS	13
MAINTENANCE	13
WIRING DIAGRAMS	14
WARRANTY	16

The Advantages of Owning This Electric Furnace

The central comfort conditioning system consists of two main parts: the outdoor unit and the indoor unit. This electric furnace is the indoor unit which can include a blower for air movement, controls, and electric heat to provide supplementary or primary comfort heating. A matching heat pump or air conditioning coil (the outdoor unit) can be added as an accessory. The electric furnace's job is to circulate conditioned air throughout the home – cool air in the summer (if an optional coil is added) and

warm air in the winter. This quality electric furnace makes a tremendous contribution to the comfort and energy efficiency of the home. It is designed to meet a variety of installation requirements. It can easily be installed in a closet, attic, or crawl space. With an available kit, it can be quickly converted to counterflow use. The superior quality, ample airflow, and quiet performance of these electric furnaces assure long term satisfaction and comfort.

SPECIFICATIONS

Physical and Electrical Data

Model	Voltage/ Hz/Phase	Blower Motor HP	Blower Motor Speeds	Max. Duct Static	Rated Load Amps	Nominal Tonnage	Maximum Heat Pump Tons	Weight (lbs.)
EFV08SB	208-230/60/1	1/3	Variable	.4	2.4	1-1/2 to 2	2	78
EFV12SB	208-230/60/1	1/2	Variable	.4	2.7	2-1/2 to 3	3	85
EFV14MB	208-230/60/1	1/2	Variable	.4	3.0	3-1/2	3-1/2	93
EFV16MB	208-230/60/1	3/4	Variable	.4	3.5	4	4	96
EFV20LB	208-230/60/1	3/4	Variable	.4	4.3	5	5	104

Cased Multi-Position Coil Match*

Electric Furnace Model	Coil Model Number
EFV08SB	CAM24, CAM30
EFV12SB	CAM30, CAM36
EFV14MB	CAM48N, CAM60N
EFV16MB	CAM48N, CAM60N
EFV20LB	CAM60, CAM61

* Refer to Specifications literature for ARI listed combinations and ratings.

Field-Installed Heater Kit Data

Electric Furnace Unit Sizes	Kit Part Number	Kit Model Number	kW Heat
EFV08, 12	44786-001	AHEFN05A-1	5
EFV08, 12, 14	44786-002	AHEFN07A-1	7.5
EFV08, 12, 14, 16, 20	44786-003	AHEFN10A-1	10
EFV12, 14, 16, 20	44786-004	AHEFC12A-1	12.5
EFV12, 14, 16, 20	44786-005	AHEFC15A-1	15
EFV12, 14, 16, 20	44786-006	AHEFC20A-1	20
EFV16, 20	44254-021	AHEFC25A-1	25

Electrical Data (Electric Furnace with or without Field-Installed Heater)

Electric Furnace Model	Field-Installed Heater Model	Number of Circuits	kW per Circuit 240 V			Minimum Circuit Ampacity per Circuit*			Maximum Fuse or Breaker		
			1	2	3	1	2	3	1	2	3
EFV08SB	None (EFV alone)	1	---	---	---	3.9	---	---	15	---	---
	AHEF05A	1	5.0	---	---	30.0	---	---	30	---	---
	AHEF07A	1	7.5	---	---	43.0	---	---	45	---	---
	AHEF10A	1	10.0	---	---	56.0	---	---	60	---	---
EFV12SB	None (EFV alone)	1	---	---	---	3.9	---	---	15	---	---
	AHEF05A	1	5.0	---	---	30.0	---	---	30	---	---
	AHEF07A	1	7.5	---	---	43.0	---	---	45	---	---
	AHEF10A	1	10.0	---	---	56.0	---	---	60	---	---
	AHEF12A	2	7.5	5.0	---	43.0	26.0	---	45	30	---
	AHEF15A	2	10.0	5.0	---	56.0	26.0	---	60	30	---
	AHEF20A	2	10.0	10.0	---	56.0	52.0	---	60	60	---
EFV14MB	None (EFV alone)	1	---	---	---	5.1	---	---	15	---	---
	AHEF07A	1	7.5	---	---	44.0	---	---	45	---	---
	AHEF10A	1	10.0	---	---	58.0	---	---	60	---	---
	AHEF12A	2	7.5	5.0	---	45.0	26.0	---	45	30	---
	AHEF15A	2	10.0	5.0	---	58.0	26.0	---	60	30	---
	AHEF20A	2	10.0	10.0	---	58.0	52.0	---	60	60	---
EFV16MB	None (EFV alone)	1	---	---	---	5.4	---	---	15	---	---
	AHEF10A	1	10.0	---	---	58.0	---	---	60	---	---
	AHEF12A	2	7.5	5.0	---	45.0	26.0	---	45	30	---
	AHEF15A	2	10.0	5.0	---	58.0	26.0	---	60	30	---
	AHEF20A	3	10.0	10.0	---	58.0	52.0	---	60	60	---
	AHEF25A	3	10.0	10.0	5.0	58.0	52.0	26.0	60	60	30
EFV20LB	None (EFV alone)	1	---	---	---	5.4	---	---	15	---	---
	AHEF10A	1	10.0	---	---	58.0	---	---	60	---	---
	AHEF12A	2	7.5	5.0	---	45.0	26.0	---	45	30	---
	AHEF15A	2	10.0	5.0	---	58.0	26.0	---	60	30	---
	AHEF20A	3	10.0	10.0	---	58.0	52.0	---	60	60	---
	AHEF25A	3	10.0	10.0	5.0	58.0	52.0	26.0	60	60	30

* Circuit #1 amps includes motor load; 2 and 3 circuit models require multiple power supplies.

Refer to the National or Canadian Electric Code to determine wire, fuse, and disconnect size requirements.

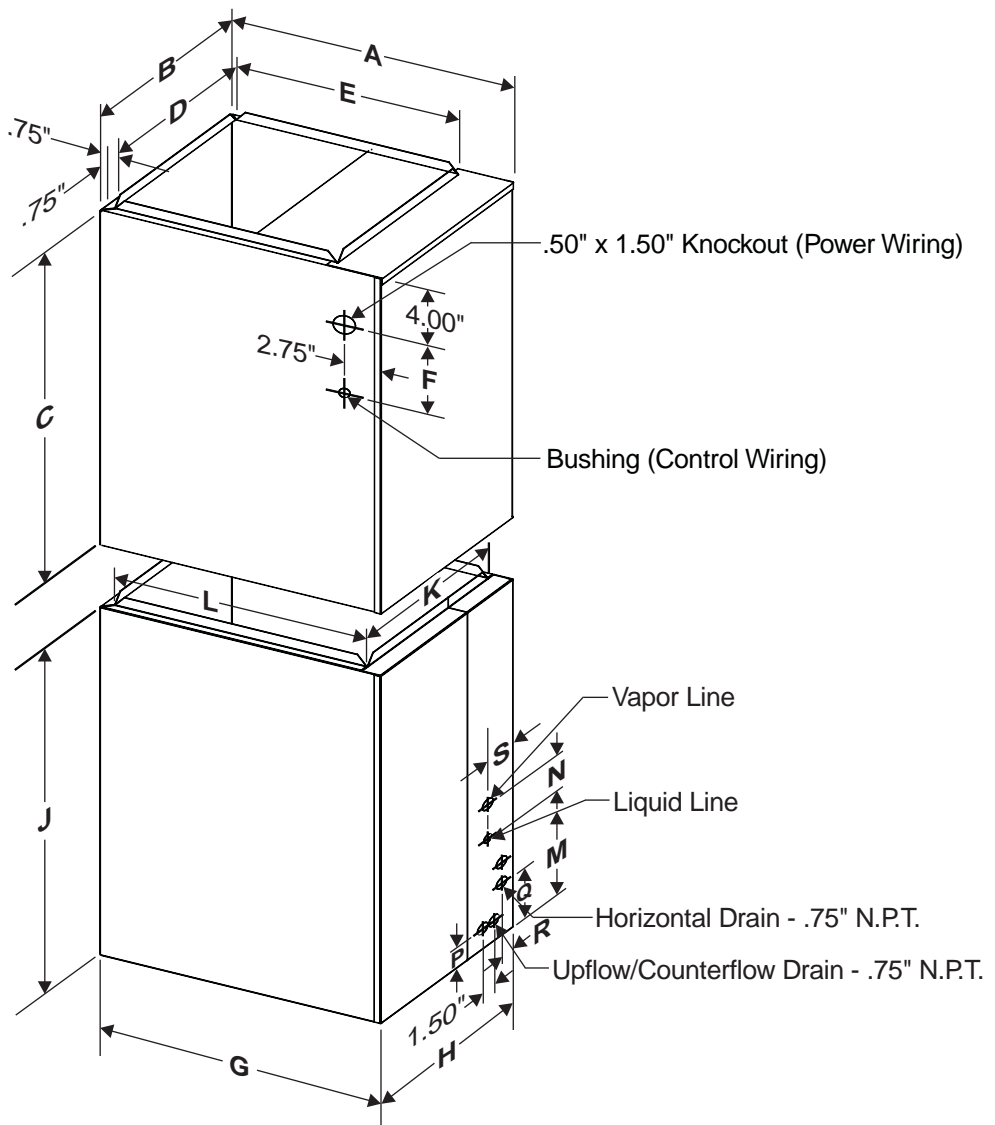

Dimensions (in.)

Electric Furnace	A	B	C	D	E	F
EFC, EFV08	21-1/2	17-1/2	24-1/2	16	17	5-1/2
EFC, EFV12	21-1/2	17-1/2	24-1/2	16	17	5-1/2
EFC, EFV14	21-1/2	22	27-1/2	20-1/2	17	8-1/2
EFC, EFV16	21-1/2	22	27-1/2	20-1/2	17	8-1/2
EFC, EFV20	26	22	27-1/2	20-1/2	20-3/4	8-1/2

Coil Section	G	H	J	K	L	M	N	P	Q	R	S
CAM24A	21-1/2	17-1/2	25-1/2	16	20	7-7/8	2-1/2	1-1/2	3-7/8	2	3-3/8
CAM30A	21-1/2	17-1/2	25-1/2	16	20	7-1/2	4-1/2	1-1/2	3-7/8	2	3-3/8
CAM26A	21-1/2	17-1/2	25-1/2	16	20	7-1/2	4-1/2	1-1/2	3-7/8	2	3-3/8
CAM48NA	21-1/2	22	29-1/2	20-1/2	20	10-1/8	5-1/2	1-1/2	6	2	3-3/8
CAM60NA	21-1/2	22	29-1/2	20-1/2	20	13-7/8	3	1-1/2	6	2	2-1/2
CAM60A	26	22	29-1/2	20-1/2	24-1/2	12-3/8	5-1/2	1-1/2	6	2	3-3/4
CAM61A	26	22	29-1/2	20-1/2	24-1/2	3-7/8	2-1/2	1-1/2	6	2	11

Airflow Configurations

Models

CAM24A	CAM48NA
CAM30A	CAM60A
CAM36A	CAM61A

Models

CAM60NA

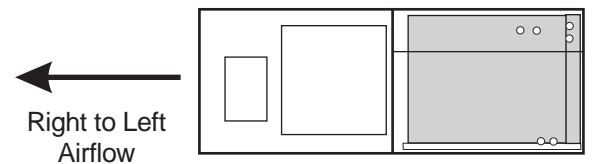
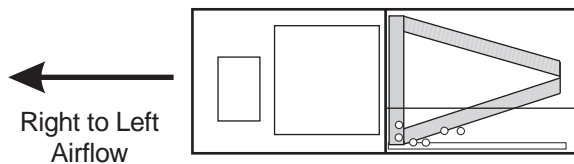
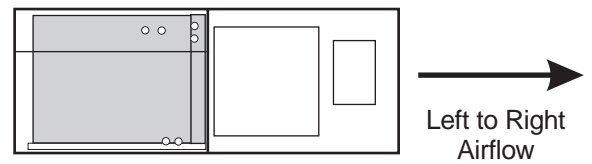
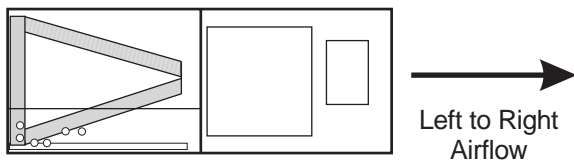
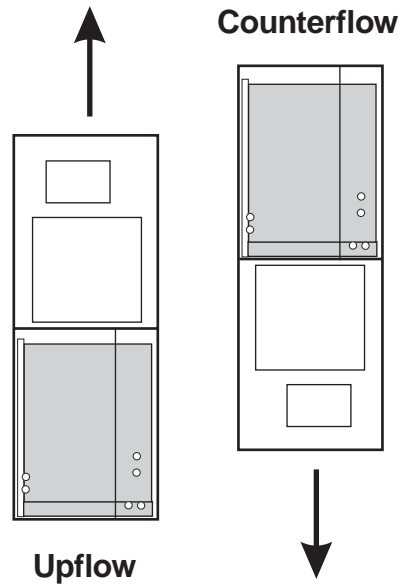
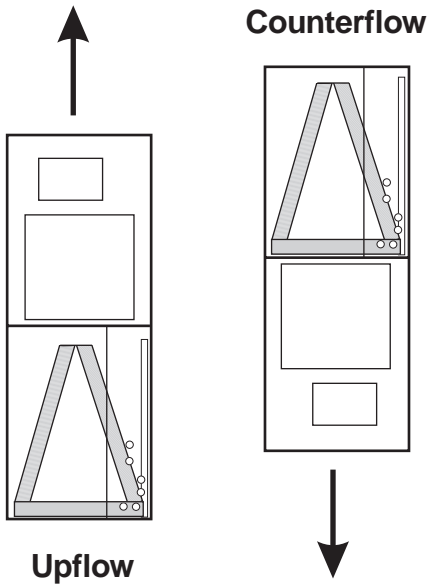

Horizontal

Horizontal

INSTALLATION

This variable speed, constant CFM, electric furnace is designed for ease of installation featuring horizontal, upflow, and downflow (counterflow) applications. The units are shipped from the factory completely assembled. Accessories may also be ordered as field-installed items. **All models are designed for indoor installations only.**

Read the entire instruction manual before starting the installation. Several of the installation steps can be done prior to setting the unit in place and doing this can save time and simplify installation. **Do not remove the cabinet knockouts until it has been determined which knockouts will need to be removed for the installation.** Determining which knockouts to remove will depend on application and in some cases preference.

These instructions are intended to be a general guideline and do not supersede any local or national codes. Installation must conform with the local building codes and with the latest editions of the National Electric Code or Canadian Electric Code.

Improper installations not following these instructions can result in unsatisfactory operation and/or dangerous conditions and may void the unit warranty.

General Information

The EF electric furnace may be used with optional mating CAM coil cabinets in upflow, counterflow, or horizontal applications (see **Airflow Configurations** on page 5 for acceptable system configurations). Tie-plates and the necessary hardware are packaged with the blower sections to connect the furnace and coil section cabinets together.

To avoid drain pan overflow of CAM coil cabinets, the web must be removed from inside any threaded drain pan hole to which a drain line is to be connected. Use care when removing the web so as to not damage the coil.

To avoid property damage caused by condensate drain blockage, install a field fabricated auxiliary drain pan with a separate drain line to the outside under any indoor electric furnace where condensate overflow could occur. If local building codes apply, install per those codes.

An optional electric heater may be installed in this cabinet.

Select the best position which suits the installation site conditions. Take into consideration required clearances, space, routing requirements for refrigerant line, condensate disposal, filters, ductwork, wiring, and accessibility for service. Refer to **Unit Dimensions** on page 4 and the unit rating plate for specific information.

These electric furnaces are completely factory assembled and all components are performance tested. Each unit consists of a blower assembly, optional refrigerant coil, and controls, in an insulated galvanized factory finished enclosure, and may also include electric heat as specified. Knockouts are provided for electrical power wiring entrance.

When used on cooling applications, excessive sweating may occur when unit is installed in a very humid space.

If installed in an unconditioned space, sealant should be applied around the power wires, control wires, refrigerant tubing, and condensate lines where they enter the cabinet. Power wires should be sealed on the inside where they exit the conduit opening. Sealant is required to prevent air leakage into and condensate from forming inside the unit, control box, and on electrical controls.

The unit must be installed in such a way as to allow free access to the coil compartment and blower/control compartment.

The unit must be installed in a level position to ensure proper condensate drainage. Make sure unit is level in both directions within 1/8".

Units with circuit breakers installed in the vertical position must have breaker switch position "ON" in the up position and switch position "OFF" in the down position. This is necessary to meet agency certification and National Electric Codes requirements.

Conversion to Vertical Downflow

The EF furnace may be converted for vertical downflow applications. The circuit breaker(s) must be rotated 180°. **To comply with certification and the National Electric Code, units with circuit breakers installed in the vertical position must have circuit breakers installed so that the breaker switch "ON" position and marking is up, and "OFF" position and marking is down.**

All electric furnaces installed with a mating coil section must follow the instructions listed below for proper condensate drainage. **It is recommended that the auxiliary drain be connected to a drain line for all units.** If the auxiliary drain is not connected, it must be plugged with provided cap. **For counterflow units, the auxiliary drain must be connected and routed to a drain.**

Horizontal Installations

Horizontal installations can be left or right hand. Adequate support must be provided to insure cabinet integrity. Ensure that there is adequate room to remove service and access panels if installing in the horizontal position. Refer to the air flow configuration drawings on page 5 for correct horizontal coil installations.

Ductwork and Airflow

Maintain all required clearances to combustible surfaces as stated on the unit rating plate.

Supply and return ductwork must be adequately sized to meet the system's air requirements and static pressure capabilities. Ductwork should be insulated with a minimum of 1" thick insulation with a vapor barrier in conditioned areas or 2" minimum in unconditioned areas. Connect supply air duct to the flange on top of the unit. If an isolation connector is used, it must be non-flammable.

Sheet metal ductwork run in unconditioned spaces must be insulated and covered with a vapor barrier. Fibrous ductwork may be used if constructed and installed in accordance with SMACNA Construction Standard on Fibrous Glass Ducts. Check local codes for requirements on ductwork and insulation.

Duct system must be designed within the range of external static pressure the unit is designed to operate against. It is important that the system airflow be adequate. Make sure supply and return ductwork, grilles, special filters, accessories, etc. are accounted for in total resistance.

Supply plenum is attached to the duct flanges supplied on the unit around the blower outlet.

Supply plenum should be the same size as the flanged opening provided around the blower outlet and should extend ideally at least 3' from the unit before turning or

branching off plenum into duct runs. The plenum forms an extension of the blower housing and minimizes air expansion losses from the blower.

If an elbow is included in the plenum close to the unit, it must not be smaller than the dimensions of the supply duct flange on the unit.

Non-Ducted Return Closet Installation

The cabinet can be installed in a closet with a false bottom to form a return air plenum or be installed with a return air plenum under the unit. Louvers or return air grilles are field supplied. Local codes may limit application of systems without a ducted return to single story buildings.

- Install louvers in a closet. Use the free area of louver or grille to determine the size opening required to provide the free area for metal louvers or grilles.
- If the free area is not known, assume a 25% free area for wood or a 75% free area for metal louvers or grilles.
- If the return air plenum is used, the return air grille should be immediately in front of the opening in the plenum to allow for the free flow of return air.
- When not installed in front of the opening, there must be adequate clearance around the unit to allow for the free flow of return air.

Recommended Remote Filter Sizes

Nominal Tons Air Conditioning & Nominal Air Flow	Square Inch Surface Area & Nominal Size		Minimum Return Air Free Area
	Disposable Filters	Washable Filters	
Up thru 2 Tons 800 - 900 CFM	432 Square Inches 20" x 25"	260 Square Inches 15" x 20"	260 Square Inches
2-1/2 Tons 900 - 1000 CFM	480 Square Inches 20" x 30"	288 Square Inches 14" x 25"	288 Square Inches
3 Tons 1300 - 1500 CFM	576 Square Inches 14" x 25" (2)	346 Square Inches 16" x 25"	346 Square Inches
3-1/2 Tons 1300 - 1500 CFM	672 Square Inches 16" x 25" (2)	404 Square Inches 20" x 25"	404 Square Inches
4 Tons 1500 - 1700 CFM	768 Square Inches 20" x 25" (2)	461 Square Inches 20" x 25"	461 Square Inches
5 Tons 1900 - 2100 CFM	960 Square Inches 20" x 30" (2)	576 Square Inches 24" x 25"	576 Square Inches

Table 1

Condensate Drain Connection

Do not operate unit without a drain trap. The condensate drain is on the negative pressure side of the blower; therefore, air being pulled through the condensate line will prevent positive drainage without a proper trap.

To avoid drain pan overflow, the web must be removed from inside any threaded drain pan hole to which a drain line is to be connected. Use care when removing the web so as to not damage the coil.

On horizontal units, the primary drain connection is flush with the bottom of the inside of pan. Auxiliary connection is raised above the bottom of the inside of the pan. Plastic web covering 3/4" auxiliary connection must be broken out if used. Do not get primary and auxiliary connections interchanged.

When making drain fitting connections to the drain pan, hand tighten only. Overtightening the fittings can split connections on the drain pan.

The unit is provided with 3/4" FPT condensate drain connections.

- Connect the drain lines to the appropriate drain pan fittings.
- Secondary drain connections should be connected to a separate drainage system.
- Install a trap in the drain line below the bottom of the drain pan and pitch the drain lines down from the coil at least 1/4" per foot of run. Horizontal runs over 15' long must also have an anti-siphon air vent (stand pipe), installed ahead of the horizontal run. An extremely long horizontal run may require an oversized drain line to eliminate air trapping.
- Route to the outside or to an appropriate drain. Check local codes before connecting drain line to an existing drainage system.
- Insulate drain lines where sweating could cause water damage.
- The removal of cabinet knockouts required for drain connections can be made much easier with the indoor coil assembly removed from the cabinet.
- Install drain lines so they do not block service access to front of unit. A 24" clearance is required for filter, coil, or blower removal and service access.
- Make sure unit is level or pitched slightly toward primary drain connection so that drain pan will empty completely without water standing in pan.

- Install a 2" trap in the primary drain line as close to the unit as practical. Make sure that the top of the trap is below connection to the drain pan to allow complete drainage of pan.
- Auxiliary drain (if used) should be run to a place where it would be noticeable if it becomes operational. Occupant should be warned that a problem exists if water should begin running from the auxiliary drain line.
- Test condensate drain pan and drain line after installation is complete. Pour several quarts of water into drain pan, enough to fill drain trap and line. Check to make sure drain pan is draining completely, no leaks are found in drain line fittings, and water is draining from the termination of the primary drain line.

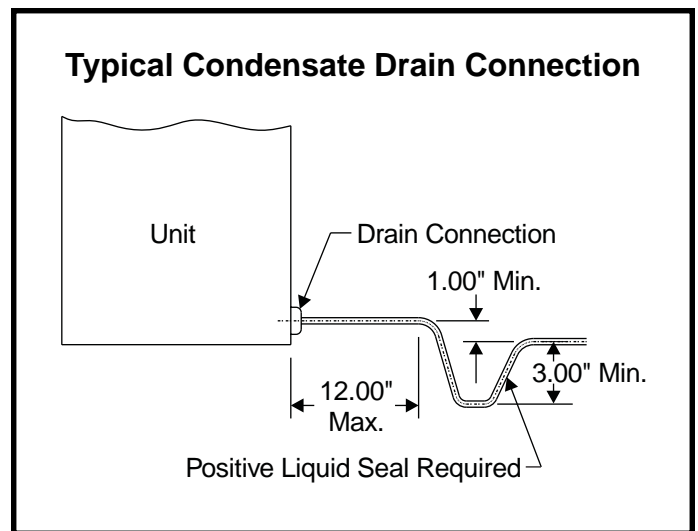

Figure 1

CAUTION

A field fabricated auxiliary drain pan, with a drain pipe to the outside of the building, is **required** in all installations over a finished living space or in any area that may be damaged by overflow from the main drain pan. In some localities, local codes may require an auxiliary drain pan for **any** horizontal installation.

Outdoor Unit

This indoor unit is designed to match and must be used with outdoor condensing units and heat pumps as per ratings. The indoor sections are manufactured with an interchangeable metering orifice or TXV to provide optimum refrigerant control and system performance with a variety of different capacities of outdoor units.

In some cases, the metering orifice must be changed to obtain rated performance. Refer to orifice information in the outdoor unit for required orifice matches.

Refrigerant Lines

Connecting refrigerant tubing must be clean, dehydrated, refrigerant grade tubing. Unit should be installed only with specified line sizes for approved system combinations with elevation differences up to 20' and total length of up to 50'. Consult outdoor equipment literature for further installation information. Care must be taken to ensure that the integrity of the tubing/system is maintained during the installation process. Keep coil connections sealed until refrigerant connections are to be made. Vapor lines must be insulated with a minimum of 3/8" rubber insulation. See outdoor unit data for details on line sizing, tubing installation, evacuation, and charging information.

When making refrigerant connections, use extreme care to protect plastic drain pan(s) from torch flame and dripping solder. Use a brazing shield to protect the drain pan during soldering. When making soldering connections close to outside of cabinet, use a brazing shield to protect the cabinet paint from being damaged by the torch flame.

Removal of the cabinet knockouts required for liquid and suction line connections may be made easier if the indoor coil assembly is removed from the cabinet.

If the installation is in a tight location, it may be convenient to make some external tubing connections before setting unit in place.

Install refrigerant tubing so it does not block service access to front of unit. A 24" clearance is required for filter, coil, or blower removal and service access.

Changing the Metering Device

It is important that the proper piston size be used dependent on indoor coil/outdoor unit combination and application.

Consult the outdoor unit information to determine if the indoor unit has the correct metering device installed. If a change of the orifice is required, loosen the retainer nut and separate the retainer tube assembly. Remove the orifice with a piston extractor tool from the replacement orifice kit. Insert the proper piston orifice into the body seal end first. Care should be taken to ensure the orifice is free in the body prior to replacement of the retainer. Torque the retainer nut to 20 – 30 ft. lbs. **Overtightening the retainer nut will crush the gasket and may result in a system leak or stuck piston.**

The orifice metering assembly must be cooled during the brazing process. The recommended method is to wrap the body with a wet rag. Indoor unit and connecting tubing

should be purged with dry nitrogen through the service port on the outdoor unit during tubing connection. All copper connection points should be brazed with an alloy of silver or copper and phosphorus with a melting point of not more than 1100° F. **Do not use soft solder.** Leak test all braze joints.

Evacuate tubing and indoor unit through service ports to 150-micron level or less.

Outdoor units are factory charge with the proper charge amount for matching evaporator and 15' of refrigerant tubing. Adjustment of refrigerant charge may be necessary based on system combination and line length. See charge instructions with outdoor unit to determine the proper system charge.

Pack insulating material around refrigerant lines where they penetrate the structure to protect tubing and minimize vibration transmission, and seal with permagum or RTV.

Electrical Wiring

WARNING

Turn off electric power at the fuse box or service panel before making any electrical connections and ensure a proper ground connection is made before connecting line voltage. Failure to do so can result in property damage, personal injury, or death.

All field wiring must be done in accordance with National Electrical Code recommendations, local codes, and applicable requirements of UL; or in accordance with the Canadian Electrical Code, local codes, and CSA Standards. Power wiring, disconnecting means, and over-current protection are to be supplied by the installer. See the **Physical and Electrical Data** tables on pages 2 and 3 as well as the unit rating plate for unit maximum over-current protection, minimum circuit ampacity, and operating voltage. The power supply must be sized and protected according to the specifications supplied. Use of multiple supply circuits require grounding of each circuit to lug(s) provided in unit.

Use copper conductors only.

The unit must be grounded with separate ground connector(s). See the electrical connection diagrams on pages 14 and 15 for typical field wiring connection. High voltage pigtail wiring connections are included in the unit. For systems requiring additional electric heat, this plug-in harness will be discarded and the high voltage connection will be made on field wire points on the heater kit. Low voltage control wiring are pigtail leads located outside the cabinet and are color coded to match the connection called out on the wiring schematic.

These units are designed for operation with a 208-240 volt single phase, 60 cycle, AC power supply. The units are internally factory wired for 240 volt installation. If 208 volt installation is desired, it will be necessary to change the black transformer lead in the blower cabinet control box to the 208V terminal on the transformer.

IMPORTANT: This variable speed motor contains DC filter capacitors that will cause a surge or inrush of current when power is applied. Power is to remain applied to the motor except during servicing. Remove AC power before plugging or unplugging the input power to the motor. Do not install blower relays that interrupt line voltage to the motor.

Variable Speed Features

The EFV electric furnace is equipped with a variable speed motor and will deliver a constant airflow within a wide range of external static pressures. The variable speed blower offers the following comfort features:

Soft Start

When called into operation, the variable speed motor will slowly ramp up to normal operating speed. This eliminates the noise and discomfort that results caused by the initial blast of air encountered with standard electric furnaces. It can take up to 7.5 minutes to reach normal operating speed.

Continuous Blower Operation

The comfort level of the living space can be enhanced when using this feature by allowing continuous circulation of air in between calls for cooling or heating. The circulation of air occurs at 50% of the normal airflow rate (350 CFM minimum).

Reduced Airflow Operation

For situations where humidity control is a problem, the variable speed motor can be enabled to operate at a 10% reduction in the normal airflow rate. This can be achieved by connecting to a standard humidity control that is normally closed and opens on humidity rise.

SETUP PROCEDURE

Locate the motor control board in the blower control box. Set the HEAT and COOL CFM taps by moving the board jumpers to the A, B, C, or D positions (see Figure 2) based on the information found in the **Application Table** on page 11. The ADJUST tap on the control board can be used to raise or lower the table CFM's. The (+) tap will raise the table CFM by 10%, and the (-) tap will lower the table CFM by 12%. **IMPORTANT: When changing the control taps, the high voltage must be off in order for the new settings to take effect.**

This model is designed for use with heat pumps as well as air conditioning systems. The motor control board needs to sense a signal on the "O" thermostat wire in order to use cooling delay timing. For a straight air conditioning system, connect the "O" wire to the 24 volt "R" wire.

The motor control board that provides airflow selection also features LED indicators that display operating mode, humidity control, and airflow CFM. In addition, thermostat signals for emergency heat (EM), aux. heat (W1), reversing valve (O), compressor (Y1), and blower (G) are all indicated by lit LED's on this board. If a humidistat is used, the dehumidify LED will light when the humidistat opens and the motor runs at reduced airflow. The control board also has a CFM LED that displays the operating CFM. This red LED flashes once for each 100 CFM. For example, if the operating CFM is 1200, the CFM LED will flash 12 times, then pause before repeating the 12-flash pattern.

Special note for units equipped with a humidistat: If using a humidistat, the dehumidify resistor located on the bottom right of the control board must be removed (see Figure 2). The HUM terminal on the board must be connected to the Normally Closed contact of the humidistat so that the board senses an open circuit on high humidity.

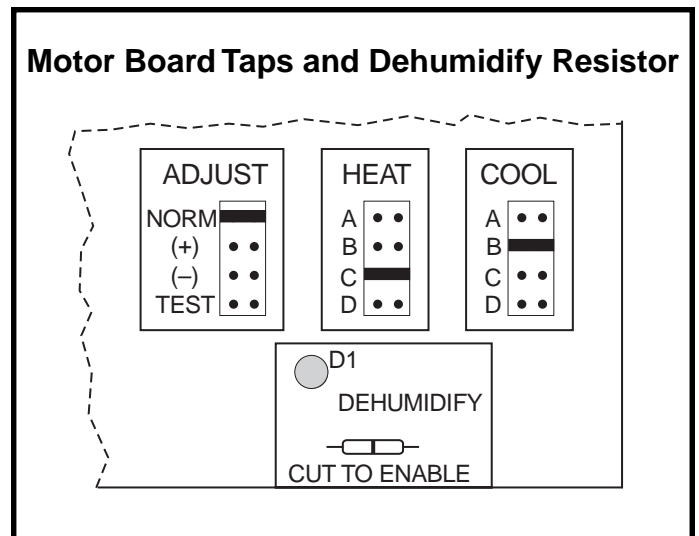

Figure 2

Application Table

The versatility of the variable speed motor enables the EFV electric furnace to tailor its performance to the different modes of operation encountered in heating and cooling. All EFV electric furnaces are capable of operation at more than one nominal airflow rate. The operation of an EFV blower at different airflow rates is determined by the

control board taps and the thermostat (see the **Application Table** below). Before beginning the setup, become familiar with the information found in this table.

The data in the application table is categorized by unit size and mode of operation. Use the information provided to determine the CFM taps needed for cooling and heating.

Application Table

Model	Mode	Thermostat						Control Board Taps							
		HUM	EM	W1	O	Y2/Y1	G	COOL				HEAT			
								A	B	C	D	A	B	C	D
CFM	CFM	CFM	CFM	CFM	CFM	CFM	CFM	CFM	CFM	CFM	CFM	CFM	CFM		
EFV08SBA	Cont. Blower						X	500	400	375	375				
	Cooling	**			X	X		1000	800	700	600				
	Heating					X		1000	800	700	600				
	Aux. Heat***			X		X		***	***	***	***	1000	800	700	600*
	Emer. Heat***		X	X				***	***	***	***	1000	800	700	600*
EFV12SBA	Cont. Blower						X	600	500	400	350				
	Cooling	**			X	X		1200	1000	800	600				
	Heating					X		1200	1000	800	600				
	Aux. Heat***			X		X		***	***	***	***	1200	1100*	1100*	1100*
	Emer. Heat***		X	X				***	***	***	***	1200	1100*	1100*	1100*
EFV14MBA	Cont. Blower						X	750	700	600	500				
	Cooling	**			X	X		1500	1400	1200	1000				
	Heating					X		1500	1400	1200	1000				
	Aux. Heat***			X		X		***	***	***	***	1500	1400	1200*	1200*
	Emer. Heat***		X	X				***	***	***	***	1500	1400	1200*	1200*
EFV16MBA	Cont. Blower						X	900	800	750	700				
	Cooling	**			X	X		1800	1600	1500	1400				
	Heating					X		1800	1600	1500	1400				
	Aux. Heat***			X		X		***	***	***	***	1800	1700	1600*	1500*
	Emer. Heat***		X	X				***	***	***	***	1800	1700	1600*	1500*
EFV20LBA	Cont. Blower						X	1000	950	900	800				
	Cooling	**			X	X		2000	1900	1800	1600				
	Heating					X		2000	1900	1800	1600				
	Aux. Heat***			X		X		***	***	***	***	2000	1800	1700	1700
	Emer. Heat***		X	X				***	***	***	***	2000	1800	1700	1700

NOTES:

* This CFM is not approved for use with highest kW heater size.

** Humidistat will reduce cooling air flow by 10% in high humidity.

*** Airflow is greater of COOL and HEAT when both electric heat and heat pump are operating.

ADJUST tap (+) will increase airflow by 10%, while tap (-) will decrease airflow by 12%.

ADJUST tap TEST will cause the motor to run at 70% of full airflow. Use this for troubleshooting only.

At the start of a call for cooling there is a short run at 82% of airflow for 7.5 minutes.

At the end of a call for cooling there is a blower delay of 1 minute.

Table 2

SEQUENCE OF OPERATION

Cooling (cooling only or heat pump)

When the thermostat calls for cooling, the circuit between R and G is completed, and the blower relay is energized. The Normally Open contacts close, causing the indoor blower motor to operate. The circuit between R and Y is also completed; this circuit closes the contactor in the outdoor unit starting the compressor and outdoor fan motor. Circuit R and O energizes the reversing valve switching it to the cooling position. (The reversing valve remains energized as long as selector switch is in the COOL position).

Heating (electric heat only)

When the thermostat calls for heat, the circuit between R and W is completed, and the heater sequencer is energized. A time delay follows before the heating elements and the indoor blower motor come on. Units with a second heat sequencer can be connected with the first sequencer to W on the thermostat sub-base or connected to a second stage on the sub-base.

Heating (heat pump)

When the thermostat calls for heat, the circuits between R and Y and R and G are completed. Circuit R-Y energizes the contactor starting the outdoor fan motor and the compressor. Circuit R and G energizes the blower relay starting the indoor blower motor.

If the room temperature should continue to fall, the circuit between R and W_1 is completed by the second stage heat room thermostat. Circuit R- W_1 energizes a heat sequencer. The completed circuit will energize supplemental electric heat. Units with a second heater sequencer can be connected with the first sequencer to W_1 on the thermostat or connected to a second heating stage W_2 on the thermostat sub-base.

Emergency Heat (heating heat pump)

If selector switch on thermostat is set to the emergency heat position, the heat pump will be locked out of the heating circuit, and all heating will be electric heat. A jumper should be placed between W_2 and E on the thermostat sub-base so that the electric heat control will transfer to the first stage heat on the thermostat. This will allow the indoor blower to cycle on and off with the electric heat when the fan switch is in the AUTO position.

SYSTEM CHECK

Pre-start Check

- Is unit properly located, level, secure, and serviceable?
- Has an auxiliary pan been provided under the unit with separate drain for units installed above a finished ceiling?
- Have all webs been carefully removed from the drain connections that are being used?
- Has the condensate line been properly sized, run, trapped, pitched, and tested?
- Is the ductwork correctly sized, run, taped, and insulated?
- Have all cabinet openings and wiring been sealed?
- Is the indoor coil metering orifice size correct?
- Is the filter clean, in place, and of adequate size?
- Has the indoor/outdoor unit application been reviewed for proper motor dip switch settings?
- Is the wiring tight, correct, and to the wiring diagram?
- Is the unit properly grounded and protected (fused)?
- Is the thermostat correctly wired, level, and in a good location?
- Is the unit circuit breaker(s) rotated properly – ON up/OFF down?
- Are all access panels in place and secure?

Refer to outdoor unit installation instructions for system start-up instructions and refrigerant charging instructions.

Airflow

For proper system operation, the airflow through the indoor coil should be between 350 – 450 CFM per ton of cooling capacity. Each electric furnace is shipped configured to provide the correct airflow for the maximum tonnage outdoor unit. If the electric furnace is to be used with smaller tonnage outdoor equipment, the variable speed motor must be configured for that application by field changing the motor control board (refer to the **Application Table** on page 11).

Electric Heater

MAINTENANCE

To check the electric heater operation:

1. Set thermostat to call for auxiliary heat (approximately 5° F above ambient temperature). The indoor blower and auxiliary heat should come on together. Allow a minimum of 3 minutes for all sequencers to cycle on.
2. Set the thermostat so it does not call for heat. Allow up to 5 minutes for all sequencers to cycle off.

REPLACEMENT PARTS

Use only original equipment service parts when repairing these products. These parts include but are not limited to: circuit breakers, heater controls, heater limit controls, heater elements, motor, blower relay, control transformer, blower wheel, indoor coil, and sheet metal parts.

When ordering replacement parts, it is necessary to order by part number and include with the order the complete model number and serial number (see unit data plate). Refer to the parts list for unit component part numbers.

Air Filters

Important: Do not operate system without a filter. A filter is required to protect the coil, blower, and internal parts from excessive dirt and dust.

See unit position figures for location of filter in unit cabinet and service panel giving access to unit filter.

Inspect air filters at least once a month and replace or clean as required. Dirty filters are the most common cause of inadequate heating or cooling performance. Replace disposable filters. Washable filters can be cleaned by soaking in mild detergent and rinsing with cold water. Install new/clean filters with the arrows on the side pointing in the direction of airflow.

Never replace a washable (high velocity) filter with a disposable (low velocity) filter unless return air system is properly sized for it.

Owner Record

Furnace Model # _____ Serial # _____ Installation Date _____

INSTALLED BY:

Dealer _____

Address _____

Telephone # _____ License # _____

Contact Person _____

Other Equipment Installed:

Equipment Type _____

Model # _____ Serial # _____ Installation Date _____

Equipment Type _____

Model # _____ Serial # _____ Installation Date _____

Equipment Type _____

Model # _____ Serial # _____ Installation Date _____

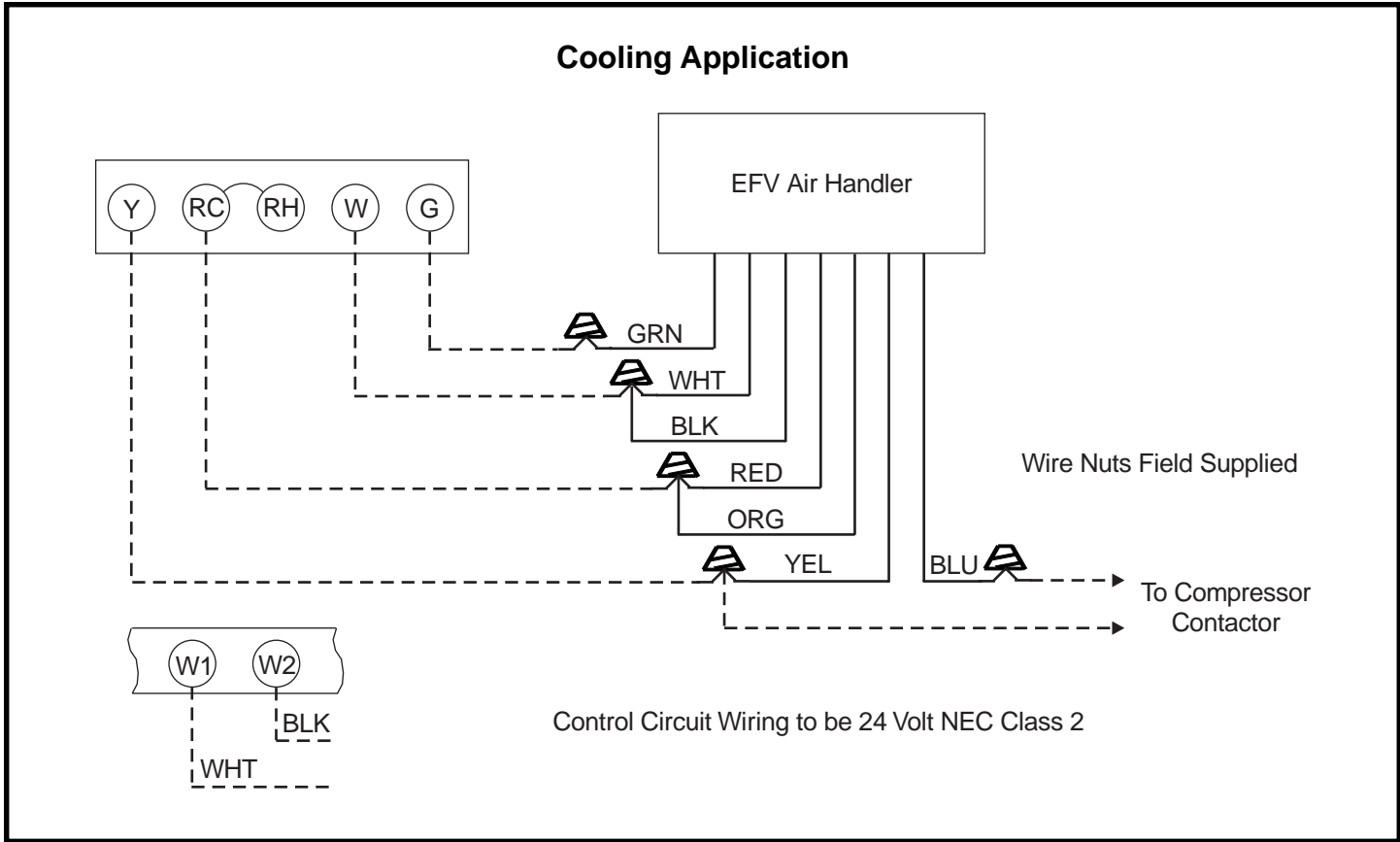

Figure 4

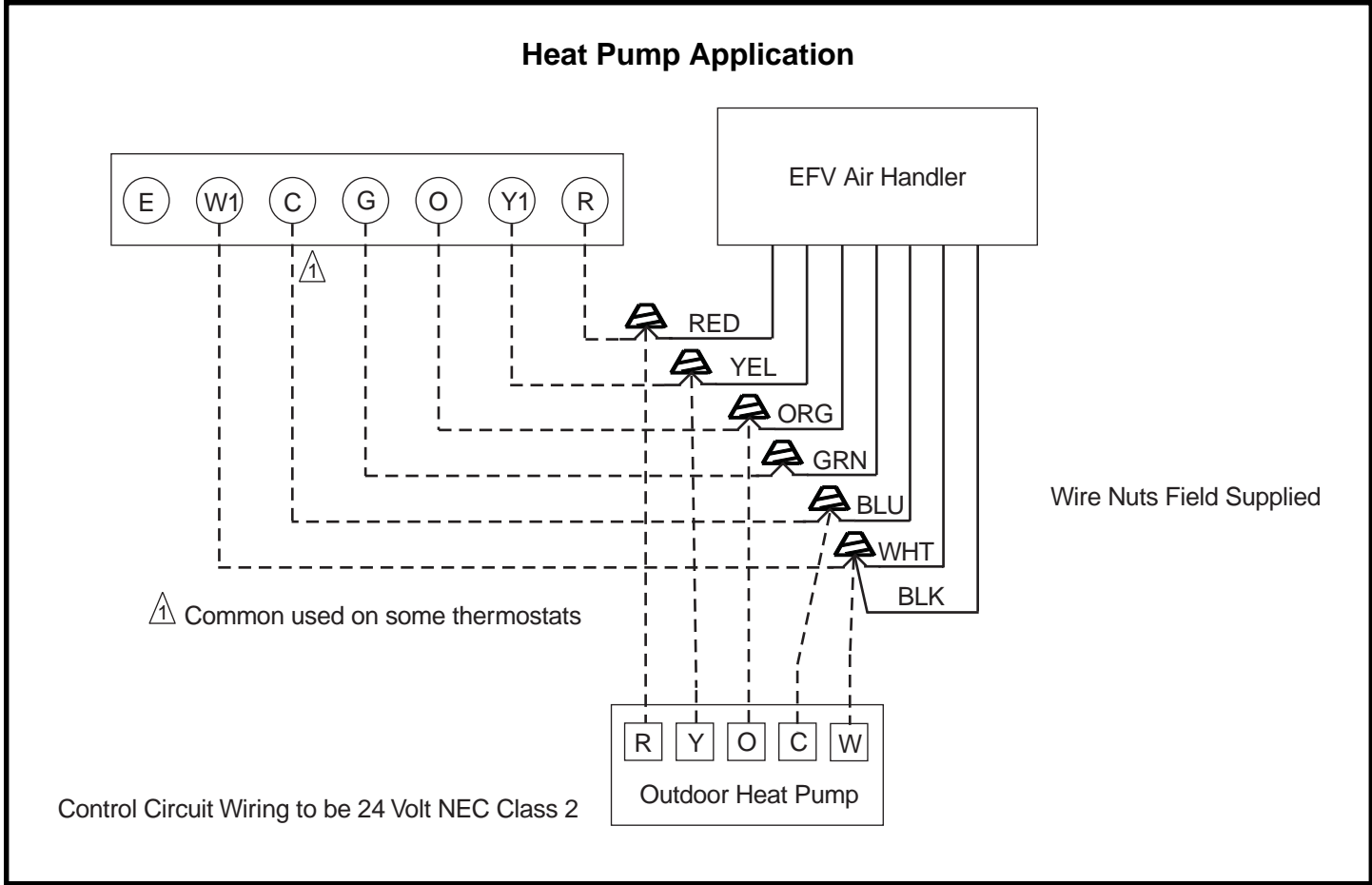

Figure 5

Limited Warranty

August 1, 1997

This warranty gives you specific legal rights and you may have other rights which vary from state/province to state/province.

Warrantor: Armstrong Air Conditioning Inc., 421 Monroe St., Bellevue, OH 44811

Armstrong Air Conditioning Inc. products are available under the following names: Air Ease, Armstrong Air, American Aire, Concord

Subject to the limitations stated in this warranty, we warrant to the first buyer for use the residential heating, cooling or heat pump unit, when installed, operated and maintained as required by this warranty, to be free of defects in workmanship or material for a period of five years (1 year for commercial equipment) from the time of installation. We will replace any defective component without cost or expense to you except for the costs of delivery and labor for removal and replacement of the defective component.

Warranty Begins

The warranty period begins when the installation is complete and the product is ready to operate. You must be able to verify this date whenever a warranty claim is made. Original bill of sale, installer's invoice or other similar document will suffice. If the beginning date cannot be verified, we will consider warranty coverage to begin six months after the date the product was shipped from our factory.

Limitations on Implied Warranties

Implied warranties of merchantability or, to the extent applicable, fitness for a particular purpose are limited to five years, the same duration as the basic limited written warranty provided herein. Some states/provinces do not allow limitations on how long an implied warranty of merchantability or fitness lasts, so the above limitations or exclusions may not apply to you.

Only Warranty

This written Limited Warranty is the only warranty made by the warrantor; this warranty is in lieu of and excludes all other warranties, express or implied. The warrantor does not authorize any person to provide any other warranty or to assume for it any further obligation in connection with the warranted product.

What is NOT Covered

1. Cabinets or cabinet pieces.
2. Normal maintenance items such as filters, fan belts, fuses or other consumable items.
3. Damage caused by misuse, failure to maintain properly, accidents or acts of God.
4. External wiring, piping, venting or attachment of accessory products not integral to our product, including without limitation, humidifier, air cleaner, vent damper, thermostat or other mechanical devices not manufactured by the warrantor.
5. Products that have been operated in a corrosive atmosphere where a concentration of acids, halogenated hydrocarbons or other corrosive elements causes deterioration to metal surfaces or integral components. NOTE: Operation in a corrosive atmosphere is considered abuse and voids this warranty.
6. Products that have NOT been installed in accordance with our published installation instructions, applicable local, state/provincial or national codes, ACCA published standards.
7. Products that have NOT been installed by competent, qualified installers.
8. Products that have been moved from their original place of installation.

Warranty on Replacement Components

Any replacement component furnished by us will assume the remaining (unused) portion of the Limited Warranty.

Consequential Damages

The warrantor shall not be responsible for any consequential damages caused by any defect in the product. Some state/provinces do not allow the exclusion or limitations of incidental or consequential damages, so the above limitation or exclusion may not apply to you.

NOTE: After the first year, in the event that a gas or oil heat exchanger is no longer being manufactured by the warrantor, the warrantor will allow a credit equal to the then current wholesale price of an equivalent heat exchanger towards the purchase of a new Armstrong gas or oil furnace.

This product must be installed, used and cared for in accordance with the instruction manual. You are responsible for required periodic maintenance or service, such as changing or cleaning of air filters and lubrication or cleaning of components. Failure to properly install, operate or maintain your unit voids this warranty.