

ELECTRIC COOLING /
ELECTRIC HEATING
PACKAGED UNIT



FORM NO. MCE4-100 (01/2021)



MODEL NUMBER GUIDE

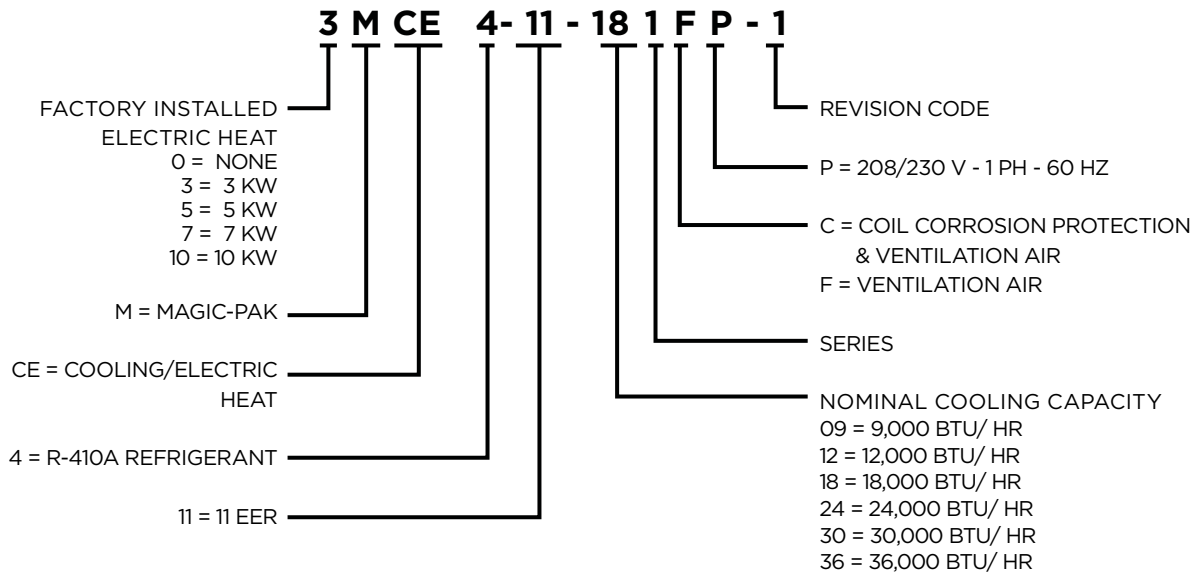

* Check that equipment complies with all applicable building codes, laws, and regulations for its intended use prior to installation.

CONTENTS

APPLICATIONS	3
UNIT APPROVALS	3
WARRANTY (RESIDENTIAL AND COMMERCIAL)	3
STANDARD FEATURES	3
OPTIONS & ACCESSORIES	4
FACTORY-INSTALLED OPTIONS.....	4
FIELD-INSTALLED ACCESSORIES.....	5
UNIT ELECTRICAL AND PHYSICAL DATA	6
UNIT DIMENSIONS (IN.)	7
MINIMUM CLEARANCES	8
OUTDOOR SOUND RATING & CABINET AIR LEAKAGE	9
FACTORY FILTER SIZE (IN.) AND PRESSURE DROP (IN. W.C.)	9
OPTIONAL VENTILATION AIR CAPABILITY	9
WALL SLEEVES & LOUVERS	10
SCCR ACCESSORY	11
MOTORIZED VENTILATION DAMPER	11
CRANKCASE HEATER	11
RATED COOLING & HEATING PERFORMANCE	12
EXTENDED COOLING PERFORMANCE DATA	13
BLOWER PERFORMANCE	14

APPLICATIONS

- Magic-Pak units are designed for use in all multifamily residential and commercial applications, such as: apartments, condominiums, student housing and senior living
- Installation in conditioned and non-conditioned mechanical spaces

UNIT APPROVALS

ETL (INTERTEK)

- Design certified by ETL Intertek to latest edition of UL 1995
- Certified for the U.S. and Canada
- Certified for less than 1.4% cabinet air leakage using ASHRAE Standard 193
- Factory-installed electric heaters are ETL listed for the U.S. and Canada
- Rated and tested in accordance with DOE test procedures and Federal Trade Commission (FTC) labeling regulations
- Rated with a 5kA Short Circuit Current Rating (SCCR) in accordance with RMS Symmetrical per UL 508A
- Refer to Unit Electrical and Physical Data table for additional details

AHRI/DOE

- Certified to AHRI Standard 390 for single package vertical units (SPVAC); refer to the AHRI Directory for AHRI certificates
- Cooling system rated in accordance with Department of Energy (DOE) test procedures

CORROSION PROTECTION

- Coating is specifically designed for use on HVAC type coils and demonstrates 6800+ hours of Sea Water Acetic Acid Testing (SWAAT) per ASTM G85:A3

SOUND RATING

- Outdoor sound level measurements tested per ANSI/AHRI Standard 270
- Refer to Outdoor Sound Rating & Cabinet Air Leakage table for additional details

LOUVER - PAINT SPECS

- Standard and impact-resistant louvers meet AAMA 2605 specifications

WARRANTY (RESIDENTIAL AND COMMERCIAL)

COMPRESSOR

- Five (5) years limited parts warranty

ALL OTHER COVERED COMPONENTS

- Refer to Equipment Limited Warranty for additional details

STANDARD FEATURES

AIRFLOW CHOICE

- Factory shipped ready for top supply and return duct connections
- Field-adaptable free return configuration, which may utilize the top or the front as return points
- Front access panel doubles as cover for top return (except 3.0 ton)

ELECTRICAL CONNECTIONS & GAUGE PORTS

- Line voltage knockouts (two concentric) to accommodate field required wire size
- Thermostat connections are located at the top of the cabinet
- Two gauge ports are located within the lower compartment of the unit
- Refer to Unit Dimension figure for additional details

CABINET

- Embossed steel cabinet
- Indoor section of the cabinet insulated with 0.5 in. dual density fiberglass insulation
- Outdoor section of the cabinet insulated with 0.5 in. weather-resistant polystyrene insulation

INTERNAL FILTER

- Tool-less filter access
- Factory-installed 1 in. filter rack with washable filter
- Field-provided filters up to MERV 6 can typically be installed in the unit's factory filter location in lieu of washable filter, when proper duct design is applied
- If a higher resistance filter is field installed in the unit, the added resistance must be included in the external static pressure and must not exceed 0.5 in. w.c. including ductwork
- Refer to Factory Filter Size and Pressure Drop and Blower Performance tables for additional details

VENTILATION AIR

- Units are outfitted with ventilation air openings and are shipped with the openings sealed
- Refer to Optional Ventilation Air Capability table and Optional Field-Installed Accessories section for additional details
- Check that equipment complies with all applicable building codes, laws, and regulations for its intended use prior to installation

REFRIGERATION SYSTEM

- Factory charged with R-410A refrigerant
- Factory sealed and tested
- Refer to Unit Electrical and Physical Data table for additional details

Indoor and Outdoor Coils

- Copper tube with aluminum fin coils

High Pressure Switch

- Shuts off unit if abnormal operating conditions cause the refrigerant discharge pressure to rise above acceptable levels

Low Pressure Switch

- Provides loss of charge protection by shutting off unit if refrigerant liquid pressure falls below acceptable levels

TRANSFORMER

- Rated for 40VA
- Factory wired for 230/240V power supply, and includes field selectable terminal for 208V
- Converts line voltage to 24V for the thermostat and control circuits within the unit

SUPPLY AIR BLOWER**ECM Constant Torque Blower Motor**

- Electrically efficient motor for reduced electrical consumption
- Motor provides specified air volume at 0.1 in. - 0.5 in. w.c. external static pressure
- Motor is resiliently mounted for quiet operation
- Blower assembly is easily removed for servicing
- Refer to Blower Performance tables for additional details

Electronic Blower Control

- Dedicated blower speed taps for continuous fan, cooling, and heating operation are programmed for optimal airflow and controlled by 24V thermostat signals
- Blower speed adjustment is easily accomplished by speed tap selection
- Fixed blower delays have been selected to enhance comfort
- Refer to Blower Performance tables for additional details

OUTDOOR COIL FAN

- Heavy duty, fully enclosed and weatherproof
- Aluminum fan blades

CONDENSATE MANAGEMENT**Primary Drain Pan**

- Antimicrobial protection: drain pan is injected with an antibacterial agent that destabilizes the membrane of microorganism cells, disrupting the cellular function of odor-causing mold and bacteria so that they can no longer grow or reproduce

Overflow Protection

- Indoor drain pan overflow switch, which monitors the condensate level in primary drain pan
- Prevents units from operating if drain clogs and water is sensed

Secondary Drain Pan

- Polypropylene wall sleeve base is specifically designed to direct rain water out of the building and in the event of any restriction in the primary drain will act as a redundant overflow protection

OPTIONS & ACCESSORIES**FACTORY-INSTALLED OPTIONS****ELECTRIC HEAT**

- Mounted internal to unit cabinet
- Multiple kW sizes available; must specify the electric heating element size (0kW to 10kW)
- Optional two stage electric heat wiring on 7 & 10kW. In order to utilize this option, it will require a thermostat with single stage cooling and two stage heating
- Compatible with 208V, 230V and 240V
- Helix wound nichrome heating elements exposed directly into the air stream resulting in instant heat transfer and low element temperatures
- Cutoff limit control provides positive protection in case of excessive temperatures
- Refer to Rated Cooling & Heating Performance table for additional details

CORROSION PROTECTION

- Epoxy coated indoor and outdoor coils

FIELD-INSTALLED ACCESSORIES

WALL SLEEVES & LOUVERS

- Units must be installed with approved wall sleeve and louver accessories for safe operation and are required for all new construction installations

WALL SLEEVES (ASLEEVE)

- Penetrates the building envelope and creates a path for condenser air intake and exhaust
- Provides a sealed connection to the unit and a secure attachment foundation for the louvers
- Larger height wall sleeves may be used on smaller tonnage equipment to maintain a uniform wall opening on the building façade
- Available in 6 in. to 12 in. depths

WALL SLEEVE EXTENSION (ASLEEVEEXT4)

- Option provides an additional 4 in. of depth to the wall sleeve, for a maximum depth of 16 in.

LOUVERS

Polypropylene Louvers (ALVRP)

- Constructed from durable, corrosion-resistant plastic
- Available in four standard colors

Aluminum Louvers (ALVRAL)

- Constructed with 6063-T6 grade aluminum
- Available in anodized clear coat, primer (to be painted in the field), standard paint colors and custom colors with paint matching*

Impact-Resistant Aluminum Louvers (ALVRALC)

- 29" and 33" impact-resistant louvers are impact and wind load certified up to 186 MPH, risk categories III and IV, and wind exposures C and D (FBC Notice of Acceptance number 18-0522.03)
- Constructed with 6063-T6 grade aluminum
- Available in anodized clear coat, primer (to be painted in the field), standard paint colors and custom colors with paint matching*

CRANKCASE HEATER (ACASE841)

- Warms compressor crankcase to limit migration of liquid refrigerant back to compressor during off cycle
- Available for models with scroll compressors
- Refer to Crankcase Heater table for additional details

SHORT CIRCUIT CURRENT RATING KIT (ASCCR)

- Provides 200kA of SCCR protection
- Refer to SCCR Accessory table for additional details

FILTERS

- Field-supplied MERV 6 filters (as required by ASHRAE 62.2) can typically be applied at the unit's factory filter location

VENTILATION DAMPERS

- Optional field-installed
- Check that the equipment complies with all applicable building codes, laws, and regulations for its intended use prior to installation

MOTORIZED DAMPER W/ CONTROLLER (AVADAMP1)

- Utilizes a ventilation air control module that is field programmable to assist with meeting ASHRAE 62.2 requirements
- Once programmed with values for ventilation air amounts, the control module opens the damper in response to thermostat inputs and monitors the run time
- Upon meeting the ventilation air needs, the control module will close the damper until the start of the next cycle
- If, during an observation period it is determined that thermostat operation alone may not provide the desired ventilation air, the control module can independently operate the unit's indoor blower, in continuous fan mode, and open the damper to aid in providing ventilation air needs

MOTORIZED DAMPER W/ FIELD-SUPPLIED RELAY (AVADAMP2)

- Opens ventilation air damper during indoor blower operation and closes during blower off periods
- Requires field-supplied and installed current sensing relay to detect indoor blower operation

HYDRONIC COIL

- Option is available on OMCE models (without electric heat)
- Unit may be adapted to include a field-supplied hydronic/hot water coil

THERMOSTAT

- Required for all installations (field-supplied)
- Units are individually controlled with conventional 24V thermostat
- Thermostat must be capable of:
 - Single stage cooling and single stage heating (3 and 5 kW single stage electric heat)
 - Single stage cooling and two stage heating (7 and 10 kW two stage electric heat)
- Refer to Unit Electrical and Physical Data table for additional details

* Certain exclusions apply. Refer to louver manufacturer's literature and warranty documentation.

UNIT ELECTRICAL AND PHYSICAL DATA (208/230 Volt - 1 Phase - 60HZ)¹

Tonnage	Model	MCA ²		MOCP ³		Default SCCR (kA) ⁴	Compressor		Outdoor Fan				Indoor Blower			R410A Refrigerant Charge (oz)	Approx. Shipping Weight (lbs)
		208V	230V	208V	230V		Rated Load Amps (RLA)	Locked Rotor Amps (LRA)	Dia. (in)	Nominal RPM	Rated Load Amps (RLA)	Rated HP	Wheel D x W (in.)	Rated Load Amps (RLA)	Rated HP		
0.75	0MCE4-11-091*P	6.3	6.3	15	15	5	4.1	21	16	1125	0.9	1/8	9 x 6	0.3	1/3	40	185
	3MCE4-11-091*P	17.0	19.5	20	20									0.6			
	5MCE4-11-091*P	22.9	26.3	25	30									1.0			
1.0	0MCE4-11-121*P	7.6	7.6	15	15	5	5.0	27	16	1125	0.9	1/8	9 x 6	0.3	1/3	47	193
	3MCE4-11-121*P	17.0	19.5	20	20									0.6			
	5MCE4-11-121*P	22.9	26.3	25	30									1.0			
1.5	0MCE4-11-181*P	10.3	10.3	15	15	5	6.7	37.5	16	1125	0.9	1/8	9 x 6	1.0	1/3	60	207
	3MCE4-11-181*P	17.0	19.5	20	20									0.6			
	5MCE4-11-181*P	22.9	26.3	25	30									1.0			
	7MCE4-11-181*P	34.3	39.3	35	40									1.4			
	10MCE4-11-181*P	45.5	52.1	50	60									1.7			
2.0	0MCE4-11-241*P	13.1	13.1	20	20	5	8.7	38	18	1050	0.9	1/8	9 x 6	1.3	1/3	76	230
	5MCE4-11-241*P	22.8	26.1	25	30									0.9			
	7MCE4-11-241*P	34.8	39.8	35	40									1.8			
	10MCE4-11-241*P	46.2	52.9	50	60									2.3			
2.5	0MCE4-11-301*P	19.8	19.8	30	30	5	13.4	72.5	18	1100	1.6	1/4	10 x 8	1.4	1/2	79	256
	5MCE4-11-301*P	22.9	26.3	30	30									1.0			
	7MCE4-11-301*P	34.0	39.0	35	40									1.2			
	10MCE4-11-301*P	45.2	51.9	50	60									1.5			
3.0	0MCE4-11-361*P	21.8	21.8	35	35	5	14.7	75	18	1100	1.6	1/4	10 x 8	1.9	1/2	94	286
	5MCE4-11-361*P	22.9	26.3	35	35									1.0			
	7MCE4-11-361*P	34.1	39.1	35	40									1.3			
	10MCE4-11-361*P	45.6	52.3	50	60									1.8			

¹ Acceptable voltage range: 197 - 253V

² MCA = Minimum Circuit Ampacity

³ MOCP = Maximum Over Current Protection

⁴ SCCR = Short Circuit Current Rating; refer to SCCR Accessory table, up to 200kA

NOTE: Units are rated at 208/230V, but MOCP & MCA values are calculated at 240V

UNIT DIMENSIONS (IN.)

Model	A	B*	C	D	E	F	G	H	J	K	L	M	N
*MCE4-11-091*P *MCE4-11-121*P *MCE4-11-181*P	43-7/8	16-7/8	25-1/4	21-1/2	18-5/8	19-1/4	6	8	16	17-1/16	3/4	2-1/4	24-5/8
*MCE4-11-241*P	47-7/8	18-7/8	27-1/4	24-3/8	20-5/8	21-1/4	6	8	16	19-1/16	3/4	2-5/8	26-5/8
*MCE4-11-301*P	55-7/8	22-7/8	31-1/4	24-3/8	24-5/8	25-1/4	6	11-3/8	10-7/16	22-7/16	3-3/4	1	30-5/8
*MCE4-11-361*P	67-7/8	26-7/8	35-1/4	24-3/8	28-5/8	29-1/4	10	11-3/8	10-7/16	22-7/16	3-3/4	1	38-5/8

* Dimension B represents the height of the optional front return air duct opening

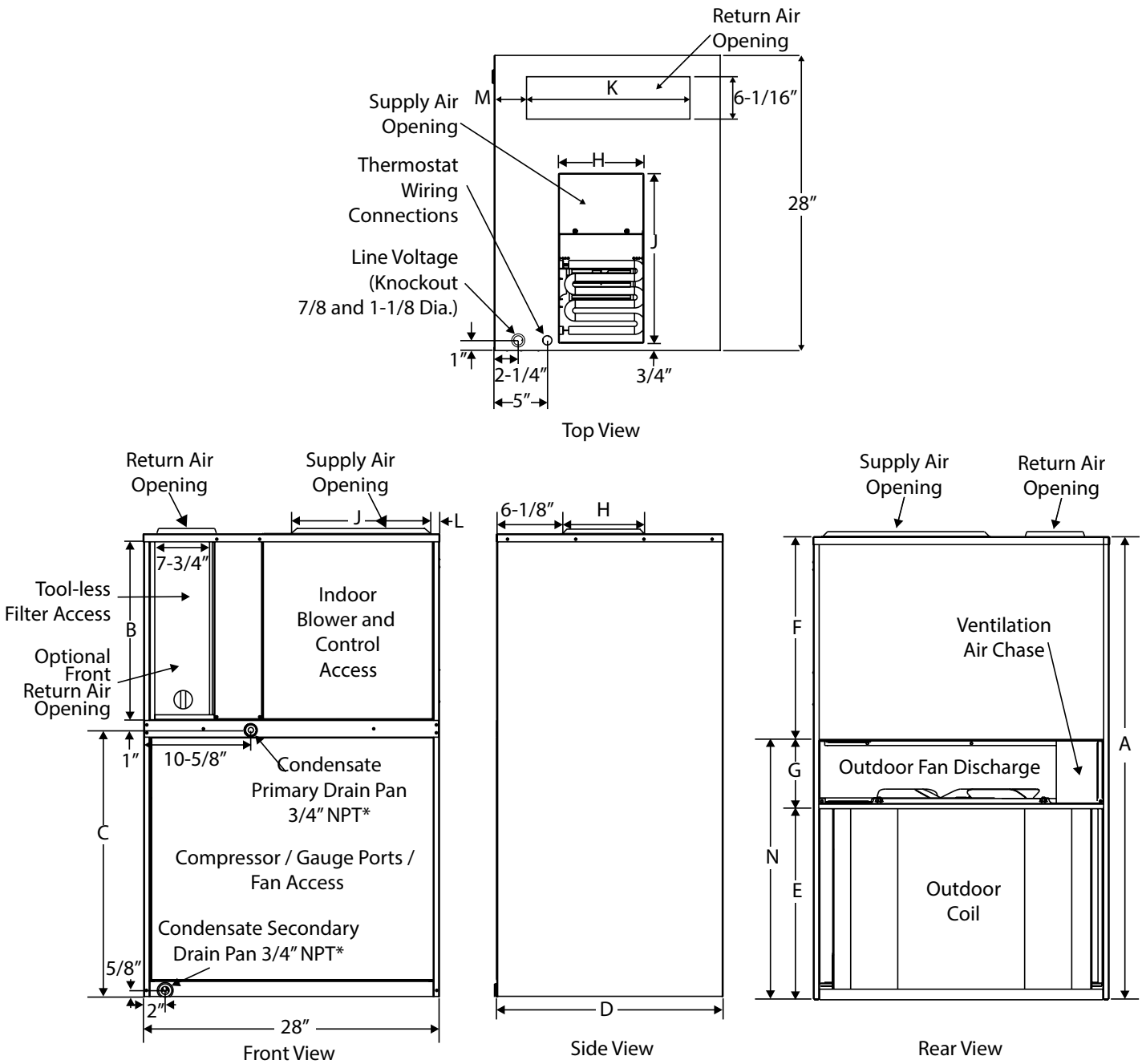

* Provisions must be made to properly drain the primary and secondary drain pan. Piping the condensate to an inside drain is required.

MINIMUM CLEARANCES

Accessibility Clearances

The front of the unit must be accessible for service. A minimum clearance of 30" in front of unit is required for service.

If the unit is enclosed, a door or access panel aligned with the front of the unit is the preferred method of providing access. The door or access panel opening must be a minimum of 30" wide (centered on the unit) and be as tall as the unit.

If a return duct is not installed, in order to provide adequate return air, the minimum clearance required between the front of the unit and the door or access panel is 4" for 43" tall cabinets and 5" for 48" and 56" tall cabinets.

IMPORTANT

The unit must be installed with approved wall sleeve and louver accessories for safe operation. Improper installations could result in property damage, personal injury, or death.

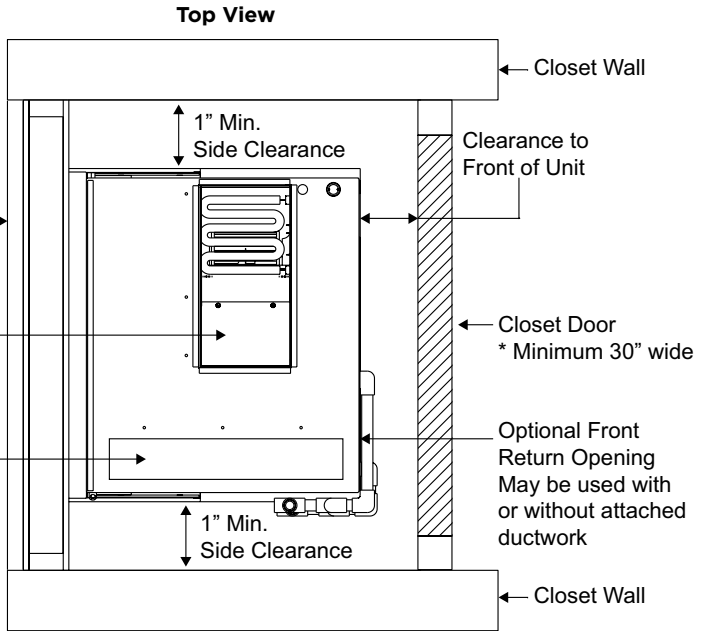

Supply Duct Clearances

Minimum Clearances to Combustible Materials ^[1]		
Front	Sides	Top
0"	0"	0"

[1] Accessibility clearances take precedence.

Unit Clearances

Return Duct Configuration	Unit Height	Minimum Clearances ^[1]	
		Front	Sides ^[3]
Connected to unit's: - Top Duct Opening, or - Optional Front Return	All	See Note 2	1"
No Return Duct (Open Optional Front Return)	43"	4"	1"
	48" or 56"	5"	1"

[1] Accessibility clearances take precedence.

[2] Clearance must accommodate field-installed condensate drain line / drain trap.

[3] Additional clearance required if field-installed condensate drain line / drain trap is routing alongside unit.

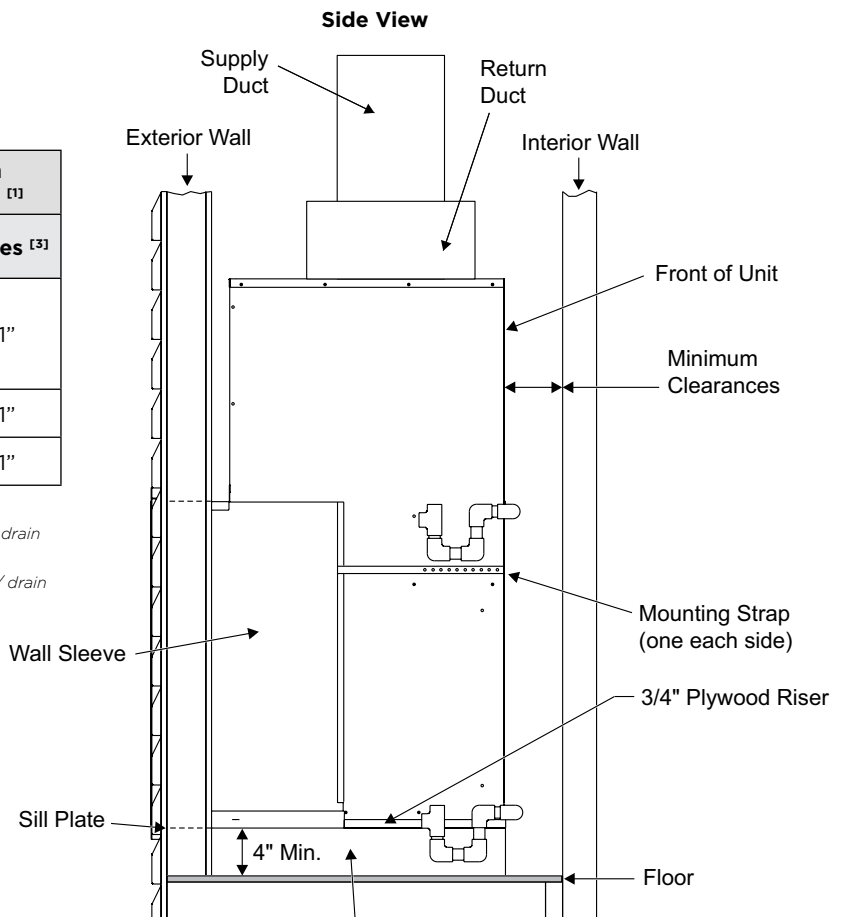

Platform (field supplied) - Unit must be supported by platform, which must be level with sill plate of opening in exterior wall.

OUTDOOR SOUND RATING & CABINET AIR LEAKAGE

Model	Outdoor Sound Rating (dBa) ¹	Cabinet Air Leakage (%) ²
*MCE4-11-091*P	73	1.4
*MCE4-11-121*P	73	1.4
*MCE4-11-181*P	73	1.4
*MCE4-11-241*P	75	1.4
*MCE4-11-301*P	79	1.4
*MCE4-11-361*P	79	1.4

¹ Per ANSI / AHRI Standard 270
² Per ASHRAE Standard 193

FACTORY FILTER SIZE (IN.) AND PRESSURE DROP (IN. W.C.)

Model	Filter Size	Supply Airflow (CFM)									
		200	300	400	500	600	700	800	900	1000	1100
*MCE4-11-091*P *MCE4-11-121*P *MCE4-11-181*P	18 x 20 x 1	0.01	0.01	0.01	0.02	0.03	0.04	0.05	---	---	---
*MCE4-11-241*P	20 x 22 x 1	---	0.01	0.01	0.02	0.03	0.03	0.04	---	---	---
*MCE4-11-301*P	24 x 22 x 1	---	---	---	0.01	0.01	0.02	0.03	0.03	0.04	0.05
*MCE4-11-361*P	28 x 22 x 1	---	---	---	---	0.01	0.01	0.02	0.02	0.03	0.03

Performance based on factory-provided washable filter installed in the unit. If a higher resistant filter is field installed in the unit, the added resistance must be included in the external static pressure and must not exceed 0.5 in. w.c. including ductwork.

OPTIONAL VENTILATION AIR CAPABILITY

Figure below shows the amount of ventilation air as a function of unit tonnage and return duct static pressure. Data is pending final testing along with low ambient operation.

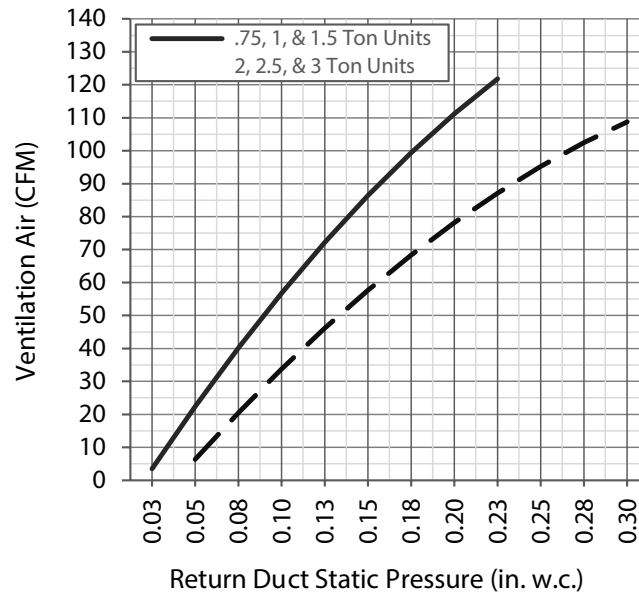

WALL SLEEVES & LOUVERS

Wall Sleeves		Louvers			Model						Dimensions (in.)			
Wall Sleeve	Wall Sleeve Extension	Polypropylene Louvers	Aluminum Louvers	Impact Louvers	*MCE4-11-091*P	*MCE4-11-121*P	*MCE4-11-181*P	*MCE4-11-241*P	*MCE4-11-301*P	*MCE4-11-361*P	Wall Sleeve	Wall Opening		
											Height (A)	Height (B)	Depth (C)	
												Sleeve Only	Sleeve Plus Extension	
ASLEEVE6-1	---	ALVRP***-1	ALVRAL-1^	ALVRALC-1^	•	•	•	•			29	29-1/8	6	---
ASLEEVE8-1	---	ALVRP***-1	ALVRAL-1^	ALVRALC-1^	•	•	•	•			29	29-1/8	8	---
ASLEEVE10-1	ASLEEVEEXT4-1	ALVRP***-1	ALVRAL-1^	ALVRALC-1^	•	•	•	•			29	29-1/8	10	14
ASLEEVE12-1	ASLEEVEEXT4-1	ALVRP***-1	ALVRAL-1^	ALVRALC-1^	•	•	•	•			29	29-1/8	12	16
ASLEEVE6-2	---	ALVRP***-2	ALVRAL-2^	ALVRALC-2^					•		32-3/4	32-7/8	6	---
ASLEEVE8-2	---	ALVRP***-2	ALVRAL-2^	ALVRALC-2^					•		32-3/4	32-7/8	8	---
ASLEEVE10-2	ASLEEVEEXT4-2	ALVRP***-2	ALVRAL-2^	ALVRALC-2^					•		32-3/4	32-7/8	10	14
ASLEEVE12-2	ASLEEVEEXT4-2	ALVRP***-2	ALVRAL-2^	ALVRALC-2^					•		32-3/4	32-7/8	12	16
ASLEEVE6-2	---	ALVRP***-2	ALVRAL-7^		o	o	o	o			32-3/4	32-7/8	6	---
ASLEEVE8-2	---	ALVRP***-2	ALVRAL-7^		o	o	o	o			32-3/4	32-7/8	8	---
ASLEEVE10-2	ASLEEVEEXT4-2	ALVRP***-2	ALVRAL-7^		o	o	o	o			32-3/4	32-7/8	10	14
ASLEEVE12-2	ASLEEVEEXT4-2	ALVRP***-2	ALVRAL-7^		o	o	o	o			32-3/4	32-7/8	12	16
ASLEEVE6-5	---	ALVRP***-3	---	---	o	o	o	o	o	•	45	45-1/8	6	---
ASLEEVE8-5	---	ALVRP***-3	---	---	o	o	o	o	o	•	45	45-1/8	8	---
ASLEEVE10-5	ASLEEVEEXT4-3	ALVRP***-3	---	---	o	o	o	o	o	•	45	45-1/8	10	14
ASLEEVE12-5	ASLEEVEEXT4-3	ALVRP***-3	---	---	o	o	o	o	o	•	45	45-1/8	12	16
ASLEEVE6-5	---	---	ALVRAL-3^	---	o	o	o	o			45	45-1/8	6	---
ASLEEVE8-5	---	---	ALVRAL-3^	---	o	o	o	o			45	45-1/8	8	---
ASLEEVE10-5	ASLEEVEEXT4-3	---	ALVRAL-3^	---	o	o	o	o			45	45-1/8	10	14
ASLEEVE12-5	ASLEEVEEXT4-3	---	ALVRAL-3^	---	o	o	o	o			45	45-1/8	12	16
ASLEEVE6-5	---	---	ALVRAL-4^	---					o	•	45	45-1/8	6	---
ASLEEVE8-5	---	---	ALVRAL-4^	---					o	•	45	45-1/8	8	---
ASLEEVE10-5	ASLEEVEEXT4-3	---	ALVRAL-4^	---					o	•	45	45-1/8	10	14
ASLEEVE12-5	ASLEEVEEXT4-3	---	ALVRAL-4^	---					o	•	45	45-1/8	12	16

Note: Wall Sleeve and Louver size must be coordinated
 *** Louver colors: WHT = white, SAN = sandstone, BGE = beige, TPST = taupestone
 ^ -P: Option to paint standard, aluminum, and impact-resistant louvers
 • Wall sleeve and louver sizes equal to the required wall opening dimensions for the unit size
 o Optional: Wall sleeves and louvers can be oversized to maintain a uniform appearance

WALL SLEEVE & WALL OPENING DIMENSIONS (IN.)

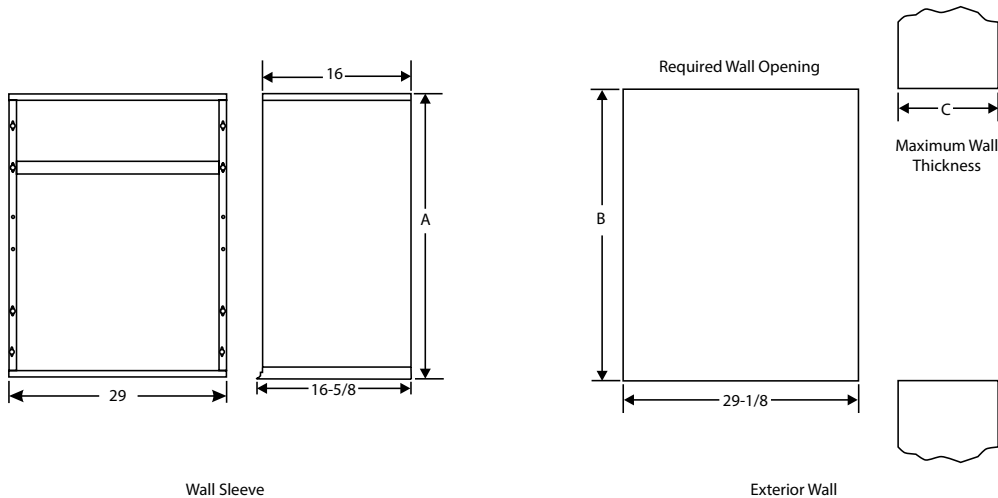

SCCR ACCESSORY

Model	Kit*
0MCE4-11-091	ASCCR1
3MCE4-11-091	
5MCE4-11-091	ASCCR2
0MCE4-11-121	ASCCR1
3MCE4-11-121	
5MCE4-11-121	ASCCR2
0MCE4-11-181	ASCCR1
3MCE4-11-181	
5MCE4-11-181	ASCCR2
7MCE4-11-181	ASCCR3
10MCE4-11-181	ASCCR5
0MCE4-11-241	ASCCR1
5MCE4-11-241	ASCCR2
7MCE4-11-241	ASCCR3
10MCE4-11-241	ASCCR5
0MCE4-11-301	ASCCR2
5MCE4-11-301	
7MCE4-11-301	ASCCR3
10MCE4-11-301	ASCCR5
0MCE4-11-361	ASCCR3
5MCE4-11-361	
7MCE4-11-361	ASCCR5
10MCE4-11-361	

* 200kA RMS Symmetrical (per UL 508A)

CRANKCASE HEATER

Model	Kit
*MCE4-11-091*P	N/A
*MCE4-11-121*P	
*MCE4-11-181*P	
*MCE4-11-241*P	
*MCE4-11-301*P	ACASE841
*MCE4-11-361*P	

MOTORIZED VENTILATION DAMPER

Model	Kit	
	AVADAMP1 (w/ Controller)	AVADAMP2 (w/ Field-Supplied Relay)
*MCE4-11-091*P	ALL	ALL
*MCE4-11-121*P		
*MCE4-11-181*P		
*MCE4-11-241*P		
*MCE4-11-301*P		
*MCE4-11-361*P		

RATED COOLING & HEATING PERFORMANCE

Tonnage	Model	Cooling				Electric Heat					
		Supply Airflow (SCFM)	Net Capacity (Btu/hr)	Efficiency (EER)	S/T [^]	240V		230V		208V	
						kW	BTU/hr	kW	BTU/hr	kW	BTU/hr
0.75	0MCE4-11-091*P	350	8,600	11.3	0.74	N/A	N/A	N/A	N/A	N/A	N/A
	3MCE4-11-091*P					3.6	12,284	3.31	11,281	2.70	9,226
	5MCE4-11-091*P					4.8	16,378	4.41	15,042	3.61	12,302
1.0	0MCE4-11-121*P	400	12,000	11.0	0.71	N/A	N/A	N/A	N/A	N/A	N/A
	3MCE4-11-121*P					3.6	12,284	3.31	11,281	2.70	9,226
	5MCE4-11-121*P					4.8	16,378	4.41	15,042	3.61	12,302
1.5	0MCE4-11-181*P	650	17,100	11.0	0.76	N/A	N/A	N/A	N/A	N/A	N/A
	3MCE4-11-181*P					3.6	12,284	3.31	11,281	2.70	9,226
	5MCE4-11-181*P					4.8	16,378	4.41	15,042	3.61	12,302
	†7MCE4-11-181*P					7.2	24,567	6.61	22,563	5.41	18,453
	†10MCE4-11-181*P					9.6	32,757	8.82	30,084	7.21	24,604
2.0	0MCE4-11-241*P	800	22,800	11.1	0.75	N/A	N/A	N/A	N/A	N/A	N/A
	5MCE4-11-241*P					4.8	16,378	4.41	15,042	3.61	12,302
	†7MCE4-11-241*P					7.2	24,567	6.61	22,563	5.41	18,453
	†10MCE4-11-241*P					9.6	32,757	8.82	30,084	7.21	24,604
2.5	0MCE4-11-301*P	1,000	28,400	11.0	0.75	N/A	N/A	N/A	N/A	N/A	N/A
	5MCE4-11-301*P					4.8	16,378	4.41	15,042	3.61	12,302
	†7MCE4-11-301*P					7.2	24,567	6.61	22,563	5.41	18,453
	†10MCE4-11-301*P					9.6	32,757	8.82	30,084	7.21	24,604
3.0	0MCE4-11-361*P	1,200	34,600	11.3	0.73	N/A	N/A	N/A	N/A	N/A	N/A
	5MCE4-11-361*P					4.8	16,378	4.41	15,042	3.61	12,302
	†7MCE4-11-361*P					7.2	24,567	6.61	22,563	5.41	18,453
	†10MCE4-11-361*P					9.6	32,757	8.82	30,084	7.21	24,604

[^] Not a rated value

[†] Two-stage heat available for 7kW and 10kW units

S/T = ratio of sensible to total cooling load

SCFM = standard cubic feet per minute

EXTENDED COOLING PERFORMANCE DATA

Tonnage	Model	Indoor Temp DB/WB (°F)	Outdoor Temperature - DB (°F)														
			65			85			95			105			115		
			Net Capacity (Btu/hr)	S/T	System Power Input (kW)	Net Capacity (Btu/hr)	S/T	System Power Input (kW)	Net Capacity (Btu/hr)	S/T	System Power Input (kW)	Net Capacity (Btu/hr)	S/T	System Power Input (kW)	Net Capacity (Btu/hr)	S/T	System Power Input (kW)
0.75	*MCE4-11-091*P	85/72	9,300	0.59	0.60	9,200	0.63	0.70	9,100	0.65	0.76	8,600	0.69	0.83	8,200	0.72	0.90
		80/67	8,700	0.65	0.59	8,600	0.71	0.70	8,600	0.74	0.75	8,000	0.79	0.83	7,500	0.84	0.90
		75/63	8,500	0.69	0.59	8,200	0.76	0.70	8,100	0.79	0.75	7,500	0.84	0.82	6,900	0.88	0.89
		75/57	7,600	0.73	0.59	6,900	0.91	0.79	6,500	1.00	0.89	6,700	1.00	0.88	6,800	1.00	0.88
1.0	*MCE4-11-121*P	85/72	14,100	0.59	0.86	13,300	0.62	1.02	13,000	0.64	1.10	12,100	0.67	1.20	11,300	0.70	1.30
		80/67	13,400	0.66	0.84	12,500	0.69	1.01	12,000	0.71	1.09	11,000	0.75	1.19	10,100	0.78	1.29
		75/63	12,800	0.69	0.84	11,700	0.73	1.00	11,200	0.75	1.08	10,200	0.78	1.17	9,200	0.81	1.26
		75/57	10,900	1.00	0.84	10,300	1.00	0.99	10,000	1.00	1.06	9,300	1.00	1.16	8,600	1.00	1.26
1.5	*MCE4-11-181*P	85/72	18,400	0.60	1.17	18,100	0.64	1.43	18,000	0.66	1.56	17,200	0.70	1.72	16,300	0.74	1.88
		80/67	17,200	0.66	1.18	17,100	0.73	1.42	17,100	0.76	1.55	16,000	0.81	1.70	15,000	0.85	1.86
		75/63	16,700	0.70	1.18	16,200	0.77	1.41	16,000	0.80	1.53	14,900	0.84	1.68	13,700	0.88	1.83
		75/57	15,800	1.00	1.17	15,500	1.00	1.40	15,300	1.00	1.51	14,300	1.00	1.66	13,300	1.00	1.80
2.0	*MCE4-11-241*P	85/72	25,900	0.61	1.55	24,900	0.65	1.89	24,300	0.67	2.06	22,900	0.70	2.27	21,400	0.73	2.47
		80/67	25,300	0.68	1.56	23,600	0.73	1.89	22,800	0.75	2.05	21,300	0.79	2.25	19,700	0.82	2.44
		75/63	23,700	0.72	1.54	22,200	0.77	1.86	21,400	0.79	2.02	19,700	0.83	2.21	18,000	0.86	2.40
		75/57	22,400	1.00	1.54	20,800	1.00	1.86	20,100	1.00	2.01	18,700	1.00	2.19	17,300	1.00	2.38
2.5	*MCE4-11-301*P	85/72	30,700	0.59	1.95	30,400	0.64	2.38	30,200	0.66	2.59	28,700	0.70	2.87	27,200	0.73	3.15
		80/67	29,700	0.66	1.94	28,800	0.72	2.37	28,400	0.75	2.58	26,500	0.79	2.85	24,700	0.82	3.13
		75/63	28,600	0.69	1.93	27,400	0.76	2.35	26,800	0.79	2.55	24,600	0.83	2.82	22,500	0.86	3.09
		75/57	27,100	1.00	1.93	26,200	1.00	2.33	25,800	1.00	2.54	23,800	1.00	2.81	21,800	1.00	3.08
3.0	*MCE4-11-361*P	85/72	38,500	0.61	2.34	37,200	0.63	2.84	36,500	0.64	3.10	34,700	0.67	3.41	32,900	0.69	3.73
		80/67	36,800	0.66	2.33	35,300	0.71	2.83	34,600	0.73	3.08	32,600	0.76	3.40	30,600	0.79	3.73
		75/63	35,500	0.70	2.33	33,600	0.74	2.81	32,600	0.76	3.06	30,400	0.80	3.37	28,200	0.83	3.69
		75/57	31,600	1.00	2.31	31,000	1.00	2.79	30,700	1.00	3.02	28,700	1.00	3.34	26,700	1.00	3.66

BLOWER PERFORMANCE

- Performance based on factory-provided washable filter installed in the unit.
- If a higher resistance filter is field installed in the unit, the added resistance must be included in the external static pressure and must not exceed 0.5 in. w.c. including ductwork
- Refer to Factory Filter Size and Pressure Drop table for additional details

SUPPLY AIRFLOW PERFORMANCE AS A FUNCTION OF EXTERNAL STATIC PRESSURE																		
Tonnage	Model	Indoor Blower Speed	0.1" w.c.			0.2" w.c.			0.3" w.c.			0.4" w.c.			0.5" w.c.			
			SCFM	Watts	HP	SCFM	Watts	HP	SCFM	Watts	HP	SCFM	Watts	HP	SCFM	Watts	HP	
0.75	*MCE4-11-091*P	TAP 1 (FAN)	355	28	0.04	320	31	0.04	275	35	0.05	230	38	0.05	160	42	0.06	
		TAP 2 (COOL)†	375	31	0.04	330	33	0.04	285	37	0.05	N/A	N/A	N/A	N/A	N/A	N/A	
		TAP 3 (COOL)	N/A	N/A	N/A	N/A	N/A	N/A	390	55	0.07	370	58	0.08	330	62	0.08	
		0 kW	TAP 4 (HEAT)*	375	31	0.04	330	33	0.04	285	37	0.05	240	40	0.05	180	44	0.06
			TAP 5 (HEAT)	465	47	0.06	425	51	0.07	390	55	0.07	370	58	0.08	330	62	0.08
		3 kW	TAP 4 (HEAT)*	430	41	0.05	410	45	0.06	385	49	0.07	N/A	N/A	N/A	N/A	N/A	N/A
			TAP 5 (HEAT)	520	58	0.08	500	63	0.08	475	68	0.09	440	73	0.10	400	77	0.10
		5 kW	TAP 4 (HEAT)*	525	59	0.08	505	65	0.09	480	69	0.09	N/A	N/A	N/A	N/A	N/A	N/A
			TAP 5 (HEAT)	615	81	0.11	590	88	0.12	560	94	0.13	530	99	0.13	500	103	0.14
		1.0	*MCE4-11-121*P	TAP 1 (FAN)	355	28	0.04	320	31	0.04	275	35	0.05	230	38	0.05	160	42
TAP 2 (COOL)†	420			40	0.05	380	42	0.06	355	46	0.06	N/A	N/A	N/A	N/A	N/A	N/A	
TAP 3 (COOL)	N/A			N/A	N/A	480	62	0.08	445	66	0.09	415	70	0.09	380	74	0.10	
0 kW	TAP 4 (HEAT)*			420	40	0.05	380	42	0.06	355	46	0.06	315	50	0.07	275	54	0.07
	TAP 5 (HEAT)			515	58	0.08	480	62	0.08	445	66	0.09	415	70	0.09	380	74	0.10
3 kW	TAP 4 (HEAT)*			430	41	0.05	410	45	0.06	385	49	0.07	N/A	N/A	N/A	N/A	N/A	N/A
	TAP 5 (HEAT)			520	58	0.08	500	63	0.08	475	68	0.09	440	73	0.10	400	77	0.10
5 kW	TAP 4 (HEAT)*			525	59	0.08	505	65	0.09	480	69	0.09	N/A	N/A	N/A	N/A	N/A	N/A
	TAP 5 (HEAT)			615	81	0.11	590	88	0.12	560	94	0.13	530	99	0.13	500	103	0.14

N/A: Do not operate unit using this blower speed at this external static pressure.

† As shipped speed for Cooling operation. Blower speed must be field adjusted to Speed Tap 3 for higher duct static applications.

* As shipped speed for Heating operation. Blower speed must be field adjusted to Speed Tap 5 for higher duct static applications.

BLOWER PERFORMANCE CONTINUED

- Performance based on factory-provided washable filter installed in the unit.
- If a higher resistance filter is field installed in the unit, the added resistance must be included in the external static pressure and must not exceed 0.5 in. w.c. including ductwork
- Refer to Factory Filter Size and Pressure Drop table for additional details

SUPPLY AIRFLOW PERFORMANCE AS A FUNCTION OF EXTERNAL STATIC PRESSURE																		
Tonnage	Model	Indoor Blower Speed	0.1" w.c.			0.2" w.c.			0.3" w.c.			0.4" w.c.			0.5" w.c.			
			SCFM	Watts	HP	SCFM	Watts	HP	SCFM	Watts	HP	SCFM	Watts	HP	SCFM	Watts	HP	
1.5	*MCE4-11-181*P	TAP 1 (FAN)	355	28	0.04	320	31	0.04	275	35	0.05	230	38	0.05	160	42	0.06	
		TAP 2 (COOL)*	660	103	0.14	640	109	0.15	610	114	0.15	580	119	0.16	550	124	0.17	
		TAP 3 (COOL)	725	131	0.18	710	135	0.18	685	140	0.19	660	146	0.20	640	152	0.20	
		0 kW	TAP 4 (HEAT)*	660	103	0.14	640	109	0.15	610	114	0.15	580	119	0.16	550	124	0.17
			TAP 5 (HEAT)	725	131	0.18	710	135	0.18	685	140	0.19	660	146	0.20	640	152	0.20
		3 kW	TAP 4 (HEAT)*	430	41	0.05	410	45	0.06	385	49	0.07	N/A	N/A	N/A	N/A	N/A	N/A
			TAP 5 (HEAT)	520	59	0.08	500	63	0.08	475	67	0.09	440	72	0.10	400	77	0.10
		5 kW	TAP 4 (HEAT)*	525	60	0.08	505	65	0.09	480	70	0.09	N/A	N/A	N/A	N/A	N/A	N/A
			TAP 5 (HEAT)	615	81	0.11	590	88	0.12	560	95	0.13	530	100	0.13	500	103	0.14
		7 kW	TAP 4 (HEAT)*	685	108	0.14	670	116	0.16	645	122	0.16	N/A	N/A	N/A	N/A	N/A	N/A
			TAP 5 (HEAT)	N/A	N/A	N/A	770	160	0.21	750	166	0.22	720	172	0.23	700	177	0.24
		10 kW	TAP 4 (HEAT)*	N/A	N/A	N/A	770	160	0.21	750	166	0.22	N/A	N/A	N/A	N/A	N/A	N/A
			TAP 5 (HEAT)	N/A	N/A	N/A	N/A	N/A	N/A	N/A	N/A	N/A	820	226	0.30	800	230	0.31

N/A: Do not operate unit using this blower speed at this external static pressure.

* As shipped speed for Cooling operation. Blower speed must be field adjusted to Speed Tap 3 for higher duct static applications.

* As shipped speed for Heating operation. Blower speed must be field adjusted to Speed Tap 5 for higher duct static applications.

BLOWER PERFORMANCE CONTINUED

- Performance based on factory-provided washable filter installed in the unit.
- If a higher resistance filter is field installed in the unit, the added resistance must be included in the external static pressure and must not exceed 0.5 in. w.c. including ductwork
- Refer to Factory Filter Size and Pressure Drop table for additional details

SUPPLY AIRFLOW PERFORMANCE AS A FUNCTION OF EXTERNAL STATIC PRESSURE																		
Tonnage	Model	Indoor Blower Speed	0.1" w.c.			0.2" w.c.			0.3" w.c.			0.4" w.c.			0.5" w.c.			
			SCFM	Watts	HP	SCFM	Watts	HP	SCFM	Watts	HP	SCFM	Watts	HP	SCFM	Watts	HP	
2.0	*MCE4-11-241*P	TAP 1 (FAN)	455	41	0.05	420	45	0.06	385	49	0.07	365	52	0.07	320	57	0.08	
		TAP 2 (COOL)†	810	146	0.20	790	158	0.21	780	166	0.22	755	173	0.23	735	179	0.24	
		TAP 3 (COOL)	870	179	0.24	860	184	0.25	845	194	0.26	815	202	0.27	785	206	0.28	
		0 kW	TAP 4 (HEAT)*	810	146	0.20	790	158	0.21	780	166	0.22	755	173	0.23	735	179	0.24
			TAP 5 (HEAT)	870	179	0.24	860	184	0.25	845	194	0.26	815	202	0.27	785	206	0.28
		5 kW	TAP 4 (HEAT)*	555	65	0.09	540	69	0.09	510	73	0.10	480	76	0.10	N/A	N/A	N/A
			TAP 5 (HEAT)	645	88	0.12	630	94	0.13	605	100	0.13	580	105	0.14	550	110	0.15
		7 kW	TAP 4 (HEAT)*	775	140	0.19	765	145	0.19	745	150	0.20	725	154	0.21	N/A	N/A	N/A
			TAP 5 (HEAT)	875	184	0.25	865	193	0.26	845	201	0.27	825	208	0.28	800	215	0.29
		10 kW	TAP 4 (HEAT)*	875	184	0.25	865	193	0.26	845	201	0.27	825	208	0.28	N/A	N/A	N/A
			TAP 5 (HEAT)	N/A	N/A	N/A	N/A	N/A	N/A	N/A	N/A	N/A	960	272	0.36	900	276	0.37
		2.5	*MCE4-11-301*P	TAP 1 (FAN)	590	42	0.06	530	48	0.06	430	55	0.07	380	60	0.08	315	65
TAP 2 (COOL)†	1015			152	0.20	985	161	0.22	940	170	0.23	910	177	0.24	875	184	0.25	
TAP 3 (COOL)	N/A			N/A	N/A	N/A	N/A	N/A	N/A	N/A	N/A	1015	219	0.29	980	227	0.30	
0 kW	TAP 4 (HEAT)*			1015	152	0.20	985	161	0.22	940	170	0.23	910	177	0.24	875	184	0.25
	TAP 5 (HEAT)			N/A	N/A	N/A	N/A	N/A	N/A	N/A	N/A	N/A	1015	219	0.29	980	227	0.30
5 kW	TAP 4 (HEAT)*			740	65	0.09	705	74	0.10	640	83	0.11	N/A	N/A	N/A	N/A	N/A	N/A
	TAP 5 (HEAT)			820	81	0.11	790	91	0.12	740	100	0.13	675	109	0.15	600	117	0.16
7 kW	TAP 4 (HEAT)*			860	91	0.12	835	100	0.13	795	108	0.14	N/A	N/A	N/A	N/A	N/A	N/A
	TAP 5 (HEAT)			945	112	0.15	925	122	0.16	885	132	0.18	845	140	0.19	800	148	0.20
10 kW	TAP 4 (HEAT)*			945	112	0.15	925	122	0.16	885	132	0.18	N/A	N/A	N/A	N/A	N/A	N/A
	TAP 5 (HEAT)			N/A	N/A	N/A	N/A	N/A	N/A	980	161	0.22	940	170	0.23	900	179	0.24

N/A: Do not operate unit using this blower speed at this external static pressure.

† As shipped speed for Cooling operation. Blower speed must be field adjusted to Speed Tap 3 for higher duct static applications.

* As shipped speed for Heating operation. Blower speed must be field adjusted to Speed Tap 5 for higher duct static applications.

BLOWER PERFORMANCE CONTINUED

- Performance based on factory-provided washable filter installed in the unit.
- If a higher resistance filter is field installed in the unit, the added resistance must be included in the external static pressure and must not exceed 0.5 in. w.c. including ductwork
- Refer to Factory Filter Size and Pressure Drop table for additional details

SUPPLY AIRFLOW PERFORMANCE AS A FUNCTION OF EXTERNAL STATIC PRESSURE																		
Tonnage	Model	Indoor Blower Speed	0.1" w.c.			0.2" w.c.			0.3" w.c.			0.4" w.c.			0.5" w.c.			
			SCFM	Watts	HP	SCFM	Watts	HP	SCFM	Watts	HP	SCFM	Watts	HP	SCFM	Watts	HP	
3.0	*MCE4-11-361*P	TAP 1 (FAN)	680	61	0.08	630	68	0.09	575	74	0.10	525	79	0.11	460	86	0.12	
		TAP 2 (COOL)†	1235	260	0.35	1200	272	0.36	1166	284	0.38	1135	295	0.40	1100	305	0.41	
		TAP 3 (COOL)	N/A	N/A	N/A	N/A	N/A	N/A	1250	330	0.44	1215	342	0.46	1180	354	0.47	
		0 kW	TAP 4 (HEAT)*	1235	260	0.35	1200	272	0.36	1166	284	0.38	1135	295	0.40	1100	305	0.41
			TAP 5 (HEAT)	N/A	N/A	N/A	N/A	N/A	N/A	1250	330	0.44	1215	342	0.46	1180	354	0.47
		5 kW	TAP 4 (HEAT)*	740	75	0.10	695	82	0.11	640	90	0.12	N/A	N/A	N/A	N/A	N/A	N/A
			TAP 5 (HEAT)	815	92	0.12	785	100	0.13	745	108	0.14	700	115	0.15	650	122	0.16
		7 kW	TAP 4 (HEAT)*	815	92	0.12	785	100	0.13	745	108	0.14	N/A	N/A	N/A	N/A	N/A	N/A
			TAP 5 (HEAT)	910	117	0.16	880	126	0.17	840	135	0.18	800	143	0.19	750	150	0.20
		10 kW	TAP 4 (HEAT)*	1010	143	0.19	980	155	0.21	945	166	0.22	N/A	N/A	N/A	N/A	N/A	N/A
			TAP 5 (HEAT)	1085	175	0.23	1065	187	0.25	1030	198	0.27	995	209	0.28	950	219	0.29

N/A: Do not operate unit using this blower speed at this external static pressure.

† As shipped speed for Cooling operation. Blower speed must be field adjusted to Speed Tap 3 for higher duct static applications.

* As shipped speed for Heating operation. Blower speed must be field adjusted to Speed Tap 5 for higher duct static applications.



215 Metropolitan Drive | West Columbia, SC 29170
800-448-5872
Product Support 866-282-7257
www.magic-pak.com

All specifications and illustrations subject to change without notice and without incurring obligations.